

**DEPARTMENT OF LABOR****Occupational Safety and Health Administration****29 CFR Part 1910**

[Docket S-029]

RIN 1218-AB80

**Walking and Working Surfaces; Personal Protective Equipment (Fall Protection Systems)****AGENCY:** Occupational Safety and Health Administration (OSHA), Labor.**ACTION:** Notice of reopening of the rulemaking record; public comment period.

**SUMMARY:** OSHA is reopening the rulemaking record on the proposed revisions to Walking and Working Surfaces and Personal Protective Equipment (Fall Protection Systems) to gather data and information concerning advances in technology and industry practice and updated consensus standards issued since the proposals were published. OSHA also is seeking comments from interested persons on specific issues concerning each proposal. The Agency will be publishing, in the future, a revised economic analysis (containing a revised regulatory flexibility analysis if necessary) for public comment. After OSHA analyzes the record from the two reopenings, the Agency will determine what other steps, if any, are necessary to finalize the rulemakings on subparts D and I.

OSHA has included the regulatory text and appendices from the 1990 proposed rule as an appendix to this limited reopening notice. This appendix may serve as an aid for stakeholders who respond to questions in this limited reopening regarding issues referencing the 1990 proposed rule.

**DATES:** Written comments must be submitted by the following dates:

*Hard copy:* Your comments must be submitted (postmarked or sent) by July 31, 2003.

*Facsimile and electronic transmissions:* Your comments must be sent by July 31, 2003.

**ADDRESSES:** *Regular mail, express delivery, hand-delivery and messenger service:* You must submit three copies of your comments and attachments to the OSHA Docket Office, Docket No. S-029, Room N-2625, U.S. Department of Labor, 200 Constitution Avenue, NW., Washington, DC 20210; telephone (202) 693-2350 (OSHA's TTY number is (877) 889-5627). OSHA Docket Office and

Department of Labor hours of operation are 8:15 a.m. to 4:45 p.m., EST.

*Facsimile:* If your comments, including any attachments, are 10 pages or fewer, you may fax them to the OSHA Docket Office at (202) 693-1648. You must include the docket number of this notice, Docket No. S-029, in your comments.

*Electronic:* You may submit comments but not attachments through the Internet at <http://ecommments.osha.gov>. (See the **SUPPLEMENTARY INFORMATION** section below for additional information on submitting comments.)

**FOR FURTHER INFORMATION CONTACT:**

*General and technical information*—Mr. Terence Smith, OSHA, Directorate of Standards and Guidance, Room N-3609, U.S. Department of Labor, 200 Constitution Avenue, NW., Washington DC 20210; telephone (202) 693-2222.

For additional copies of this **Federal Register** notice, contact OSHA, Office of Publications, Room N-3101, U.S. Department of Labor, 200 Constitution Avenue, NW., Washington, DC 20210; telephone (202) 693-1888. Electronic copies of this **Federal Register** notice, as well as news releases and other relevant documents, are available at OSHA's Web page on the Internet at <http://www.osha.gov>.

**SUPPLEMENTARY INFORMATION:****Table of Contents**

- I. Submission of Comments on This Notice and Internet Access to Comments and Submissions
- II. Background
- III. Need for Revisions to Subparts D and I
- IV. Request for Comments, Data and Information
  - A. Subpart D
    - 1. Rolling Stock and self-propelled, motorized mobile equipment
    - 2. Qualified Climbers
    - 3. Rung Width for Fixed Ladders
    - 4. Hierarchy of Fall Protection Controls
    - 5. Scaffolds and Controlled Descent Devices
    - 6. Anchors for Suspended Work
  - B. Subpart I—Personal Protective Equipment for Fall Protection
    - 1. General Fall Protection Requirement
    - 2. Body Belts for Fall Arrest
    - 3. Additional Proposed Amendments of General Industry Standards
  - C. Other Issues
    - 1. New and Updated National Consensus Standards
    - 2. Incorporation of Other Rulemaking Dockets
  - D. Updating Economic Analysis and Impact on Small Businesses
- V. Authority and Signature

**I. Submission of Comments on This Notice and Internet Access to Comments and Submissions**

You may submit comments in response to this document by (1) hard copy, or (2) FAX transmission (facsimile), or (3) electronically through the OSHA Webpage. Please note that you cannot attach materials, such as studies or journal articles, to electronic comments. If you wish to submit additional materials, you must submit three hard copies of them to the OSHA Docket Office at the address above. The additional materials must clearly identify your electronic comments by name, date, subject and docket number so we can attach them to your comments.

Because of security-related problems there may be a significant delay in the receipt of comments by regular mail. Please contact the OSHA Docket Office at (202) 693-2350 (TTY (877) 889-5627) for information about security procedures concerning the delivery of materials by express delivery, hand delivery and messenger service.

All comments and submissions will be available for inspection and copying at the OSHA Docket Office at the address above. Comments and submissions posted on OSHA's Webpage are available at <http://www.osha.gov>. OSHA cautions you about submitting personal information such as social security numbers and birth dates. Contact the OSHA Docket Office at (202) 693-2350 (TTY (877) 889-5627) for information about materials not available through the OSHA Webpage and for assistance in using the Webpage to locate docket submissions.

**II. Background**

Subpart D of 29 CFR part 1910, Walking and Working Surfaces, sets forth general industry requirements for employers to protect employees from slips, trips and falls that may cause serious or fatal injuries. Subpart I of 29 CFR part 1910, Personal Protective Equipment, contains general requirements covering the use and maintenance of personal protective equipment (PPE), as well as specific provisions on the use, design and performance requirements for various types of PPE such as eye, face, head and respiratory protection.

The standards currently in subparts D and I were part of the initial package of standards OSHA promulgated in 1971 under section 6(a) of the Occupational Safety and Health Act of 1970 (the Act) (29 U.S.C. 655). Section 6(a) directed the Secretary, within two years of the

effective date of the Act, to adopt as OSHA safety and health standards any national consensus standards, and established Federal standards that were issued under other statutes.

Soon after OSHA adopted subpart D, the Agency initiated efforts to revise the standard. In September 1973, OSHA published a proposed revision of subpart D in the **Federal Register** (38 FR 24300, September 6, 1973). In April 1976, however, OSHA withdrew the 1973 proposal (41 FR 17227, April 23, 1976) because, in the Agency's view, it had become outdated and did not reflect current industry practices.

Concurrently, OSHA published a notice requesting further information from interested parties about revising Subpart D (41 FR 17102, April 23, 1976). OSHA also conducted several informal public meetings to allow interested parties to present their views on issues related to subpart D. Based on the comments submitted in response to the notice and the public meetings, OSHA determined that a more thorough scientific and technical research effort was necessary to obtain objective information needed to develop a revised subpart D.

Thereafter, OSHA accumulated a wide variety of technical information and studies from sources such as the National Bureau of Standards (now the National Institute of Standards and Technology) and the American National Standards Institute, which the Agency used to develop the proposed revisions to subparts D and I.

On April 10, 1990, OSHA published proposals for revising the standards for subparts D (55 FR 13360) and I (55 FR 13423). The two proposals were published together because of the interdependent nature of the hazards and working conditions they address. Proposed subpart D included, among other things, revised provisions for the use of personal fall protection systems while proposed subpart I added specific design and performance criteria that various personal fall protection systems, such as body belts and harnesses, would have to meet. OSHA received 788 comments on proposed subpart D and 56 on proposed subpart I during the comment period, including several requests for an informal public hearing.

On July 18, 1990, OSHA extended the comment period for written comments on the proposed standards until August 22, 1990, and scheduled an informal public hearing (55 FR 29224).

The informal public hearing was held on September 11–14, and 17–18, 1990, in Washington, DC. Fifty-one parties presented testimony, and fifty-nine post-hearing comments were received through December 1990.

The record was closed and certified on April 20, 1992.

#### *A. Proposed Revisions of Subpart D*

The proposed rule for subpart D updated many requirements in the existing standards and proposed changes to consolidate and simplify requirements and to eliminate ambiguities and redundancies. OSHA also proposed to add a number of provisions that were not addressed in the existing standards. For example, the proposal would have added provisions allowing employers to use alternative means to protect employees from fall hazards (e.g., designated areas, personal fall protection equipment, safety nets) when guardrails and physical barriers are not feasible. The proposal also added provisions addressing walking and working surfaces such as step bolts, manhole steps and industrial truck platforms. In addition, OSHA proposed that the revised requirements would apply only prospectively, that is, the proposal would allow workplaces and equipment meeting existing subpart D requirements to be "grandfathered in" and limited application of the revised requirements to new installations and renovations.

#### *B. Proposed Revisions of Subpart I*

As noted above, subpart I contains general requirements to provide PPE as well as use, design and performance requirements for various types of PPE. Subpart I, however, currently does not contain specific design or performance requirements for personal fall protection systems.

OSHA proposed to add provisions to subpart I specifying the strength and performance requirements that all personal fall protection systems would have to meet whenever their use was required by a part 1910 standard. The proposal included design and performance criteria for several types of personal fall protection systems, including lifelines, lanyards, body belts and harnesses, work positioning systems (called "positioning device systems" in 1926 subpart M, Fall Protection in the Construction Industry), travel restricting systems and climbing device systems. In addition, OSHA proposed to add a non-mandatory appendix (Appendix C) to provide a number of test methods and procedures that employers and manufacturers could use to determine whether their systems were in compliance with the proposed design and performance requirements for fall protection systems. The primary purpose of the design criteria and test methods was to ensure that employers would use fall protection systems that

are strong enough to provide the necessary fall protection, but that do not stop falls with a level of force that could exceed human injury tolerance and injure employees.

Other OSHA standards covering specific types of workplaces and equipment in general industry currently include provisions that require employers to provide personal fall protection systems (e.g. § 1910.66, Powered platforms for building maintenance; § 1910.67, Vehicle-mounted elevated and rotating work platforms; § 1910.261, Pulp, paper and paperboard mills; § 1910.268, Telecommunications). However, only § 1910.66 of the above standards includes requirements on the design and performance criteria for personal fall protection systems. The criteria in § 1910.66 only apply to personal fall protection systems required within that standard.

Two standards do contain criteria for fall protection equipment. The fall protection standards for the construction industry (subpart M of 29 CFR part 1926), finalized in 1994 (59 FR 40672, August 9, 1994), and the personal fall protection requirements for shipyard employment (29 CFR 1915.159), issued in 1996 (61 FR 26322, May 24, 1996), have design and performance criteria that are similar to those in proposed subpart I. OSHA also notes that both of these standards prohibit the use of body belts for fall arrest. OSHA will also review comments and information received in those rulemakings in determining how to proceed with the rulemakings on Walking and Working Surfaces and Personal Protective Equipment (Fall Protection Systems).

### **III. Need for Revisions to Subparts D and I**

A review of the information, data and comments in the rulemaking record for subparts D and I as well as information OSHA has received since then, indicate that OSHA does need to revise the requirements in these subparts to address the significant hazards of slips, trips and falls to employees in general industry. Data in the record, as well as data received since the record closed in 1992, show that a significant number of accidents and fatalities in general industry are caused by slip, trip and fall hazards. For example, a 1982 study by the Bureau of Labor Statistics (BLS) showed that during a four-month period 938 employees were injured when they fell on stairs (Docket S-041; Ex. 2-37). The study was based on a review of workers' compensation data from 24 states. OSHA believes that the injury

total would have been significantly higher had data from all the states been included in the study. In 1984 and 1985, BLS reported that more than 300 workers died in fall-related accidents, which represented nine percent of all workplace deaths (Docket S-041; Ex. 2-19).

More recent publicly available data also confirm the need for revising subparts D and I. BLS data for 1999 show that employee falls resulted in 721 fatalities and 297,499 injuries involving lost workdays, and a fatality rate of 0.08 per 10,000 employees. BLS data for 2000 shows a slight increase in employee fall fatalities (734), also with a fatality rate of 0.08 per 10,000 employees. This represents a slight increase from the 1992 fatality rate of 0.06 derived from BLS data. A 2002 study by the Liberty Mutual Insurance Company found that falls to a lower level were the fourth leading cause of all workplace injuries, accounting for 9.2% of all workplace injuries and \$3.7 billion in direct costs annually (Docket S-029; Ex. 1-17).

OSHA believes that revising the standards for subpart D and adding design and performance requirements for personal fall protection equipment in subpart I will substantially reduce the number of fatalities and injuries resulting from slip, trip and fall hazards.

#### IV. Request for Comments, Data and Information

Since publication of the proposed revisions to subparts D and I, many of the resource documents OSHA used to develop the proposed rules have been updated and industry practices and equipment design and performance have improved. OSHA believes that incorporating information and data about these changes and improvements into the revisions of subparts D and I will make the revised subparts more effective in protecting employees from the hazards of slips, trip and falls. Therefore, OSHA is reopening the rulemaking record to add this information and provide the public with an opportunity to review and comment on it.

At the same time, OSHA invites comment on a range of specific issues that are related to the proposed revisions. OSHA is particularly interested in receiving comments on the questions listed below. OSHA will carefully review and evaluate data, information and comments received in response to this notice in revising proposed subparts D and I.

As previously discussed, OSHA is using this limited reopening to supplement and update the existing

rulemaking record for subparts D and I. There is a substantial public record on the proposed standards, including comments, public hearing proceedings, and post-hearing comments. This limited reopening will allow the public to update the record on a few key issues in the proposed rules, as well as to provide input for a revised economic analysis. When this revised analysis is completed, OSHA will reopen the record again to allow the public to comment on the revised analysis and the issues raised by proposed subparts D and I in light of the revised analysis. After that public comment period, OSHA will determine if any other steps are necessary, including issuance of a revised NPRM, before the Agency moves ahead with a final rule for these proposals.

To facilitate stakeholders responding to questions in this limited reopening regarding issues referencing the 1990 proposed rule, the regulatory text and appendices as proposed in 1990 have been included as an appendix to this reopening document.

##### A. Subpart D

###### 1. Rolling Stock and Self Propelled, Motorized Mobile Equipment

OSHA is requesting additional comment on whether rolling stock and self-propelled, motorized mobile equipment should be covered or excluded from subpart D. Self-propelled, motorized mobile equipment includes tractor trailer trucks, tank trucks, hopper trucks and buses while rolling stock includes covered and uncovered rail cars, hopper cars, tank cars, and trailers.

Existing subpart D does not exclude such equipment from coverage and OSHA has issued citations for self-propelled, motorized mobile equipment under this subpart. In the proposed revision of subpart D, however, OSHA proposed to exclude surfaces that were an integral part of "self-propelled, motorized mobile equipment" other than platforms lifted by powered industrial trucks (§ 1910.21(a)(1), 55 FR 13396). In the preamble, OSHA said that employee exposure to these types of surfaces was usually brief and sporadic, such as performing periodic maintenance. In addition, there was concern that the surfaces did not contain anchorage points for attaching fall protection equipment.

The preamble also included examples of equipment that OSHA intended to exclude from coverage, but did not specify whether rolling stock were included in those examples (55 FR 13365). OSHA received comments

saying that all rolling stock should be excluded from coverage (Docket S-041; Ex. 3-46).

An OSHA memorandum issued to its Regional Administrators on October 18, 1996, interpreted the proposal as excluding rolling stock from subpart D (Docket S-029; Ex. 1-16-2). In anticipation of a final revised rule, the memorandum directed OSHA inspectors not to cite rolling stock under subpart D. The memorandum also said it would not be appropriate to use the PPE standard (29 CFR 1910.132 (d)) to cite employee exposure to fall hazards on the tops of rolling stock, unless the rolling stock was positioned inside of or contiguous to a building or other structure where the installation of fall protection is feasible. The Agency is asking for additional comment on the following issues that relate to the appropriate scope of subpart D:

1. In your establishment and/or industry, how many or what percentage of employees working on top of rolling stock and/or self-propelled, motorized mobile equipment are exposed to fall hazards? How are these employees protected from fall hazards while working on such equipment? If fall protection equipment is used, please provide detailed information on the types and costs of the fall protection used on mobile equipment and please explain how it is used. If fall protection equipment is not used, please explain what technological and/or economic obstacles may be involved. Are there alternative means to protect employees from fall hazards while working on mobile equipment, including rolling stock? Please explain.

2. What is your safety experience with fall hazards on rolling stock and self-propelled, motorized mobile equipment?

3. Should OSHA exclude rolling stock and self-propelled motorized mobile equipment from coverage under subpart D? Please explain and provide data and information to support your comments.

###### 2. Qualified Climbers

OSHA proposed to add a provision to subpart D that would allow employers to use "qualified climbers," in certain limited situations, to climb fixed ladders that are not equipped with fall protection devices (*i.e.*, cages, wells or ladder safety devices) (§ 1910.23(a)(2), 55 FR 13398). The proposed provision would be an alternative to the existing subpart D requirement that fixed ladders more than 20 feet (6.1 m) high be equipped with such fall protection devices (§ 1910.27(d)). The proposed provision would allow qualified climbers to climb a ladder without fall

protection, provided that (1) the employer shows that the process of installing ladder safety devices, cages or wells on the fixed ladder would pose a greater hazard, and (2) the fixed ladder is climbed no more than twice per year (§ 1910.23(a)(2), 55 FR 13398). Once qualified climbers reach their work location, however, they must use fall protection.

In the proposal, OSHA defined as a qualified climber as “[a]n employee who, by virtue of physical capabilities, training, work experience and job assignment, is authorized by the employer to routinely climb fixed ladders, step bolts or similar climbing devices attached to structures” (§ 1910.21(b), 55 FR 13397).

OSHA recognizes that accidents involving ladders account for a significant number of workplace injuries and deaths. Indeed, OSHA estimated in its preliminary economic analysis that annually more than 10 percent of work surface injuries (11,025 injuries) and 19 percent of work surface deaths (25 deaths) involved ladders (55 FR 13390). Nonetheless, OSHA proposed the qualified climber alternative, in part, because the Agency believed that hundreds of thousands of fixed ladders were not equipped with the devices subpart D requires and were being climbed without fall protection of any kind. In the proposal, the Agency estimated that the cost of retrofitting all of these ladders to comply with subpart D could exceed \$1.5 billion (55 FR 13360).

OSHA also proposed the qualified climber concept because the Agency believed that the process of installing, inspecting and maintaining cages, wells or ladder safety devices could, in some cases, substantially increase the period of employee exposure to fall hazards, as compared to the amount of time that qualified climbers would spend actually climbing ladders that did not have such devices.

OSHA is seeking comment on several issues concerning qualified climbers:

- The number of times a fixed ladder that is not equipped with fall protection (*i.e.*, personal fall protection systems, ladder safety devices, cages, or wells) should be allowed to be climbed in a year,
- Any environmental conditions in which qualified climbers should not be allowed to climb without using fall protection,
- Whether employers should be required to provide climbers with personal fall protection systems during training, and

- The use of other work practices and devices to protect qualified climbers from falling while climbing.

*Current industry practice.* As mentioned, the proposal for subpart D would allow qualified climbers to climb fixed ladders that are not equipped with fall protection on an infrequent basis. OSHA stated in the preamble that permitting employers to use qualified climbers who are physically fit and specially trained, would be an effective way to reduce the number of falls from these fixed ladders (55 FR 13388–89). OSHA issued a compliance directive, which explained the *de minimus* policy (OSHA Instruction CPL 2.103) (Docket S–029; Ex. 1–16). Under this policy, it would be considered a *de minimus* violation when an employer complied with a proposed standard rather than the standard in effect at the time of the inspection and the employer’s actions clearly provided equal or greater employee protection. Employers who followed the proposed requirements in subpart D for qualified climbers would not be subject to citation under existing subpart D.

OSHA is interested in receiving comment on the extent to which fixed ladders are equipped with fall protection and the extent to which employers use qualified climbers.

4. In your establishment and/or industry, how many or what percentage of fixed ladders exceeding 20 feet (6.1 m) are equipped with ladder safety devices, cages, or wells? What technological and/or economic obstacles may be involved in equipping fixed ladders with cages, wells, or ladder safety devices?

5. In what percentage of climbs on fixed ladders are personal fall protection systems used? Where personal fall protection systems are used, how do climbers “tie off” to these ladders?

6. In your establishment and/or industry, to what extent (*e.g.*, what percentage) are climbs performed by qualified climbers, as defined above? How many or what percentage of their climbs are performed on fixed ladders that are not equipped with ladder safety devices, cages or wells? How many or what percentage of their climbs are performed without personal fall protection systems? What has been the safety experience in your establishment and/or industry using qualified climbers?

7. In your establishment and/or industry, what are the factors and/or rationale involved in the decision to use a qualified climber? Please explain and provide comment on both the risk-related and economic factors involved in this decision. Also, please comment

on the extent to which any of the following factors are involved in this decision: height of ladder, frequency of climb, cost of installing and maintaining fall protection equipment, and cost of training qualified climbers.

8. If you use qualified climbers, has this practice resulted in safety or productivity benefits? Please explain and provide data and information about those benefits.

*Number of climbs.* The proposal for subpart D would allow employers to use qualified climbers, in lieu of equipping fixed ladders with fall protection, provided the ladder is climbed very infrequently (1910.23(a)(2); 55 FR 13398). OSHA proposed that employers be allowed to do so where the ladder is climbed no more than twice a year. In the preamble OSHA notes that some industries (*e.g.*, outdoor advertising) allowed those ladders to be climbed more frequently and OSHA said it was considering permitting those ladders to be climbed by qualified climbers up to 12 times year before employers would be required to equip the ladders with fall protection devices (55 FR 13364). OSHA requested comment on whether the Agency should increase the number of climbs ladders that were not equipped with fall protection could be climbed by a qualified climber. Several commenters requested that OSHA allow ladders to be climbed up to six times per year before employers would be required to equip them with fall protection (Docket S–041, Exs. 3–412, 3–432, 10–6). They said six climbs would be in line with telecommunication industry practice. OSHA notes that the Electric Power Generation, Transmission and Distribution standard (Electric Power Generation standard), which was finalized after the proposal for subpart D was published, does not place a limit on the number of times that a structure can be climbed by a qualified climber without using fall protection (§ 1910.269(g)). Instead, the standard limits climbing without fall protection based on whether certain conditions such as ice, high winds, structure design, or contaminants are present that could cause employees to lose their grip or footing (59 FR 4320, 4373; Jan. 31, 1994).

In a related issue, some commenters urged OSHA to adopt a broader definition of what constitutes one “climb.” One commenter, for example, suggested defining one “job” as constituting one “climb” (Docket S–041, Tr. 9/17/90 pp. 1745–46). One job, however, could take days or weeks to complete and involve a large number of climbs. OSHA is considering whether to

define a single "climb" as any work activities at one fixed ladder location that take place within a 24-hour time period, regardless of the number of times the employee goes up and down the ladder in that time. Accordingly, a job started at 1 p.m., Monday and completed by 1 p.m., Tuesday, would count as one climb. Similarly, a job started at 1 p.m., Friday and completed by 1 p.m., Monday, would only count as one climb if Saturday and Sunday were non-workdays. OSHA solicits comment on the following issues:

9. In your establishment and/or industry, how many times or what percentages of total climbs are on fixed ladders that are not equipped with fall protection (*i.e.*, personal fall protection systems, ladder safety devices, cages or wells) during a year? What is the safety experience for such climbs in your establishment and/or industry?

10. What should be the maximum number of times that fixed ladders can be climbed without fall protection during a year? Please explain. How many or what percentage of climbs in your establishment and/or industry would be affected by changing the maximum number of times a ladder can be climbed without fall protection? Would that change significantly affect the costs of complying with proposed subpart D in your establishment and/or industry? Please provide estimates of the reductions in costs and an explanation of how those costs were derived.

11. Are there data and information on climbing injuries and fatalities to support increasing the number of times these ladders may be climbed during a year without equipping them with fall protection? Please explain and provide data and information.

12. Is there support for a definition of a single "climb" as all work activity and climbs on a single fixed ladder within a 24-hour period, regardless of the number times a qualified climber ascends and descends the ladder during that time period? Please explain and provide supporting materials.

13. Are there data and information on climbing injuries and fatalities that support the use of a 24-hour time period as constituting a single climb? Please explain and supply data and information.

*Environmental conditions.* An issue has been raised about the types of environmental conditions in which qualified climbers should not be allowed to climb without using fall protection. Neither existing nor proposed subpart D address this issue.

The Electric Power Generation standard, which also permits employers

to use qualified employees to climb or change location on poles, towers, or similar structures without using fall arrest equipment, places restrictions on the type of environmental conditions employees can climb in without using fall protection (29 CFR 1910.269(g)(2)(v)). The standard specifies that qualified employees are not allowed to climb without fall arrest equipment where "conditions, such as, but not limited to, ice, high winds \* \* \* or the presence of contaminants on the structure, could cause the employee to lose his or her grip or footing" (§ 1910.269(g)(2)(v)).

14. In your establishment and/or industry, in what types of environmental conditions do qualified climbers use personal fall protection equipment? What kinds of personal fall protection equipment do they typically use in those environmental conditions? What has been the safety experience in your establishment and/or industry with those practices?

15. Should OSHA include in subpart D a requirement similar to the one in the Electric Power Generation standard (§ 1910.269) prohibiting qualified climbers from climbing without fall protection equipment when environmental conditions are such that they could cause qualified climbers to lose their grip or footing? Please explain.

16. Should OSHA include a requirement prohibiting employees from climbing ladders in certain environmental conditions? Please explain. Under what environmental conditions should such requirements apply?

*Safe work practices.* Commenters suggested additional measures that could be implemented to protect qualified climbers. Gulf Power Company (Docket S-041; Ex. 3-83), for instance, urged OSHA to require qualified climbers have both hands free of tools or other objects when ascending or descending a ladder, which would ensure that climbers maintain three points of contact at all times when climbing.

The Electric Power Generation standard requires climbers to use fall protection if they are not able to hold onto the structure, for example, because they are carrying tools or other equipment in their hands. In the preamble to the final rule, OSHA said:

[C]limbing without the use of fall protection is only safe if the employee is using his or her hands to hold onto the structure while he or she is climbing \* \* \* Climbing in this manner will enable the employee to hold onto the structure in case his or her foot slips. If

the employee is not using his or her hands for additional support, he or she would be much more likely to fall as a result or a slip (55 FR 4374).

OSHA requests comments on the following issues:

17. What work practices, if any, have you instituted in your establishment and/or industry to protect qualified climbers during climbing? What has been the safety experience in your establishment and/or industry using those practices?

18. Should OSHA require that qualified climbers have both hands free of tools or objects when climbing? Please explain.

*Resting capability.* In the subpart D proposal, OSHA proposed requirements that would require employers to provide climbers with rest platforms during extremely long continuous climbs (§ 1910.23(c)(17), 55 FR 13399). The purpose of requiring rest platforms when continuous climbs are greater than 150 feet is to ensure that climbers do not become so fatigued that their safety becomes endangered.

Several commenters opposed the rest platform provision. One commenter (Docket S-041; Ex. 3-413) said that having rest platforms "may create a more hazardous condition," especially if built on the outside of a telecommunication tower. The commenter also said that placing the platform inside the tower might restrict the climbing area. Two commenters suggested that OSHA permit the use of ladder safety devices, body belts, lanyards or other fall protection equipment as a reasonable alternative to installing rest platforms on ladders (Docket S-041; Exs. 3-83, 3-413). One of these commenters said that fall protection equipment provides greater protection than rest platforms because "the climber can rest at any time and is not in danger of falling" (Docket S-041, Ex. 3-83). The other commenter said that rest platforms might create hazardous conditions where, because of space restrictions, they have to be built on the outside face of a tower (Docket No. S-041, Ex. 3-413). The Agency believes that it may be appropriate to allow employers to comply with the requirement to provide resting capability by equipping climbers with a short positioning-type device or lanyard that meets the requirements of proposed subpart I. OSHA believes that the alternative resting devices also may provide additional advantages because they would enable employees to rest anywhere along the length of the climb instead of only at fixed rest platforms.

19. What is currently being done in your establishment and/or industry to

ensure that climbers are able to rest during long climbs? What is the safety experience in your establishment and/or industry using those practices? Would the use of platforms introduce new hazards in your establishment and/or industry?

20. Should OSHA allow climbers to use short lanyards to tie off and rest during climbing activities? Please explain.

21. If OSHA requires climbers to be equipped with lanyards for resting during climbs, is there additional need to have permanent rest platforms installed every 150 feet on ladders? Please explain and provide data and information to support your comments.

*Fall protection during training.* The proposal for subpart D would require qualified climbers to successfully complete a training or apprenticeship program that includes hands-on training (§ 1910.32(b)(5)(ii)). A proposed non-mandatory appendix also recommends that climbers use personal fall protection equipment while training Subpart D, Appendix A; 55 FR 13408, 13420). The Electric Power Generation standard requires that trainees use fall protection "any time they are more than 4 feet (1.2 m) above the ground" (§ 1910.269(g)(2)(v)). In a note to that provision, OSHA said that fall protection during training was necessary because employees still undergoing training were not yet considered "qualified" for purposes of being covered by the exception to using fall protection during climbing. The preamble to the Electric Power Generation final rule said:

These employees would not be able to judge for themselves whether or not a safety strap should be used (and, in some cases, may not even be qualified in its use). Additionally, the record indicates that training and experience is one of the reasons a line worker can climb a pole or structure safely without fall protection \* \* \* and that employees in training are at increased risk of injury due to falling (59 FR 4374).

OSHA believes that the reasoning in the Electric Power Generation standard supporting the use of fall protection during training of qualified persons also is applicable to the training of qualified climbers, and OSHA is considering whether to incorporate the language from Appendix A into the requirements of subpart D to further enhance employee safety.

22. In your establishment and/or industry, how are employees currently protected from falls while they are being trained to be qualified climbers? What is the safety experience in your establishment and/or industry using those practices?

23. Should OSHA require that employees always use fall protection equipment while being trained to be qualified climbers? Please explain.

24. Would a requirement to provide fall protection during training significantly affect costs, revenues or overall profitability in your establishment and/or industry? Please provide estimates of impacts on costs, revenues and/or profits and an explanation of how the estimates were derived.

25. How many and what percentage of employees at your establishment would be affected by adding such a requirement?

### 3. Rung Width on Fixed Ladders

Proposed subpart D carried over from the existing subpart a requirement that ladder rungs on fixed ladders have a minimum clear width of 16 inches (41 cm) (§ 1910.23(c)(9), 55 FR 13399). OSHA also proposed to replace the ladder requirements contained in the Telecommunications standard (§ 1910.268(h)) with a cross-reference to the revised ladder requirements of proposed subpart D (55 FR 13423). The existing Telecommunications standard requires a 12-inch (31 cm) minimum clearance width for rungs on fixed ladders. Commenters from the Telecommunications industry opposed the proposed revision, saying that telecommunications towers were highly specialized structures that do not have the space available for wider ladder rungs (Docket S-041, Ex. 3-116).

26. In the telecommunications industry, how many or what percentage of fixed ladders have rungs that are less than 16 (41 cm) wide? What has been the safety experience using these ladders?

27. At telecommunication centers and field installations, should OSHA continue to allow rungs on fixed ladders to have a minimum clearance width of 12 inches (31 cm)? Please explain and provide supporting data and information.

### 4. Hierarchy of Fall Protection Controls

Existing subpart D requires guardrails to protect employees from fall hazards (§ 1910.22(c)). However, because it may not be feasible to provide guardrails in all situations, OSHA proposed to establish a hierarchy of controls for protecting employees from fall hazards under subpart D (§ 1910.28(a)(1), 55 FR 13401). Under the proposal, guardrails would be required as the primary means of fall protection. However, other fall protection methods such as personal fall protection systems, hole covers and safety nets would be permitted where

installing guardrails was infeasible. OSHA had proposed a similar provision in the 1973 proposed rule that was withdrawn. In 1978, OSHA issued a compliance directive, which is still in effect, allowing the use of alternate fall protection, which would include the use of personal fall protection, where the use of guardrails is not feasible (STD 1-1.7, October 30, 1978) (Docket S-029; Ex. 1-22).

The construction Fall Protection final rule did not have a hierarchy fall protection. The standard included a list of options any of which employers would be permitted to follow (51 FR 42718, November 25, 1986). For consistency between OSHA's construction standards and general industry standards, the Agency believes it would be appropriate to delete the hierarchy for fall protection controls in general industry. OSHA also notes that the fall protection requirements in a number of general industry standards do not establish a hierarchy of controls for protecting employees against fall hazards. See *e.g.*, § 1910.252, Welding, Cutting and Brazing General Requirements; § 1910.268, Telecommunications; § 1910.269, Electric Power Generation.

In light of this, OSHA is reconsidering whether to delete the proposed hierarchy from subpart D. OSHA recognizes that there may be many situations in which employers may find it preferable to provide guardrails. For example, if multiple employees are exposed to fall hazards on a regular basis, employers may find it is more efficient and cost-effective to install guardrails than to use personal fall protection systems.

28. Does your establishment and/or industry follow a hierarchy of controls for providing fall protection? If so, what is that hierarchy? If not, why? What is the safety experience in your establishment and/or industry using those practices?

29. In your establishment and/or industry, what types of fall protection are provided for employees?

30. Should OSHA include a provision on hierarchy of controls for fall protection in subpart D or allow employers to choose any type of fall protection in proposed § 1910.28 that the employer can demonstrate will be appropriate for the specific work location and activities being performed? Please explain. Are there certain situations in which employers should be required to follow the hierarchy of controls in protecting employees from fall hazards? Please explain and provide examples.

31. If OSHA were to eliminate the provision on hierarchy of fall protection controls, would this significantly affect the costs of complying with the proposed standard? Please provide estimates of reduction in costs to your establishment and/or industry and an explanation of how those costs were derived.

32. Please describe any changes to your fall protection program that your establishment and/or industry have implemented in the past 10 years. How many of or what percentage of employees have been affected by those changes? What was the impetus for those changes? Please describe any safety, technological, economic and potential regulatory factors that were involved in implementing those changes. For example, did any of the fall protection provisions proposed by OSHA for subparts D and I precipitate any changes to fall protection programs in your establishment and/or industry?

#### 5. Scaffolds and Controlled Descent Devices

Existing subpart D addresses 20 different types of scaffolds, ranging from wood pole scaffolds to float scaffolds (§ 1910.28). Because many of these scaffolds are not typically used in general industry, the proposal for subpart D specifically addressed only the four types of scaffolds most commonly used:

- Two-point adjustable suspension scaffolds (swing stages) (§ 1910.30(d), 55 FR 13405);
- Single-point adjustable suspension scaffolds (§ 1910.30(e), 55 FR 13406);
- Mobile manually propelled scaffolds (§ 1910.30(f), 55 FR 13406); and
- Boatswains' chair (§ 1910.30(g), 55 FR 13406).

In the preamble, OSHA explained that the 16 other types of scaffolds not specifically addressed in subpart D would be required to meet the requirements of the scaffolding standards for the construction industry (29 CFR Part 1926, subpart L) (55 FR 13378). This approach, OSHA said, would ensure coverage of all scaffolds and at the same time simplify subpart D. OSHA also requested comments about whether these other types of scaffolds should be specifically addressed in subpart D.

Several commenters from the window cleaning industry said OSHA should consider controlled descent devices (CDD) to be scaffolds, and to include them in the scaffold section of subpart D (Docket S-041; Ex. 3-45; 3-412; 10-11). A CDD is a suspension-type device that usually supports one employee in

a chair (seat board) and allows the user to descend in a controlled manner and to stop at desired points during the descent. The CDD is a variation of the single-point adjustable suspension scaffold, but generally only operates in a descending direction. Commenters said that CDDs are used in at least 60 percent of all high-rise window-cleaning operations and are not specifically covered in the scaffold standards for the construction industry (Docket S-041; Ex. 3-431).

In a March 12, 1991, memorandum to its Regional Administrators, OSHA stated that employers who use CDDs to perform building cleaning, inspection and maintenance must do so in accordance with the manufacturer's instructions, warnings, and design limitations. In addition, OSHA said it expected employers using CDDs to implement eight specific safety provisions covering the following areas: employee training, inspection of equipment, proper rigging, separate fall arrest systems, installation of lines, rescue, prevention of rope damage and stabilization (Docket S-029; Ex. 1-16-3). These eight provisions also are included in the current national consensus standard, ANSI I-14.1-2001—Window Cleaning Safety (Docket S-029; Ex. 1-13). The ANSI standard also limits the use of CDDs, which it refers to as rope descent systems (RDS), to window cleaning operations performed 300 feet (91 m) or less above grade, unless the windows cannot be safely and practicably accessed by other means such as powered platforms.

OSHA is considering adding provisions specifically addressing CDDs to subpart D. The OSHA memorandum has been in effect for more than a decade and OSHA is not aware of any fatalities involving CDDs when all eight of the safety provisions have been followed. In addition, the inclusion of the eight provisions in the ANSI standard on window cleaning indicates strong industry acceptance of these specific safety precautions.

33. In your establishment and/or industry, to what extent and in what operations are controlled descent devices being used? Please provide a detailed description of the technical, economic and safety factors that are considered in determining whether to deploy them. When controlled descent devices are used in your establishment and/or industry, are the eight safety provisions in the OSHA 1991 memorandum and ANSI I-14.1-201 being followed? If any are not being met, please explain why. What has been the safety experience in your establishment and/or industry using these devices?

34. Are controlled descent devices being used in operations performed more than 300 feet above grade? In what circumstances are controlled descent devices used above that height? Are additional safety measures used when operating at that height? Please explain. What has been the safety experience in your establishment and/or industry using the devices at that height?

35. Should OSHA include specific requirements for the use, installation and maintenance of controlled descent devices in the scaffold section of Subpart D? Please explain.

36. Should OSHA add to subpart D the eight safety provisions on the use of controlled descent devices discussed in the 1991 OSHA memorandum to Regional Administrators and included in ANSI I-14.1-2001? Please explain.

37. Should OSHA limit the use of controlled descent devices to operations performed no higher than 300 feet (91 m) above grade unless access cannot be attained safely and practicably by other means? What additional safety measures are needed for operations performed above 300 feet? Please explain.

38. Would limiting controlled descent devices to 300 feet impose added costs in your establishment and/or industry? If so, please provide estimates of the costs and an explanation of how those costs were derived.

39. How many or what percentage of jobs in your establishment or industry would be affected by such a requirement?

#### 6. Anchors for Suspended Work

Proposed subpart D includes several provisions requiring that scaffolding and personal fall protection systems be secured to structures or buildings to prevent them from swaying or moving suddenly (§ 1910.28(c)(24)(vi), § 1910.28(c)(27)(ii), § 1910.28(d)(3), 55 FR 13405). For example, proposed subpart D requires personal fall protection systems used on single-level scaffolds and the top surface of multi-level scaffolds to be attached to a structure (anchorage point) other than the scaffold or scaffold suspension system (§ 1910.28(c)(27)(ii), 55 FR 13405). However, neither existing nor proposed subpart D address the installation and maintenance of the anchorages themselves on buildings or other structures.

In the hearing notice for proposed subpart D, OSHA requested comment on whether OSHA should add an installation and maintenance provision to subpart D for "all structures where it is reasonably foreseeable that employees will need anchorage points" to attach scaffolds and other equipment (55 FR

29224, 29227–28, July 18, 1990). OSHA raised this issue after IWCA and small window cleaning companies told OSHA that quite often there were no anchorage points on rooftops for attaching their lines. Since they did not own the building, they had no control over the presence or location of anchorage points. They urged OSHA to require building owners to install anchor points on rooftops or designate existing structural members that would be strong enough to serve as anchor points to attach scaffolds, control descent devices and safety lines (Docket S–041; Exs. 3–407, Tr. 9/11/90 pp. 311, 313, 330–31; Tr. 9/12/90 pp. 483–84, 503, 543–44, 565–66, 596–97, 629–30).

Building Owners and Managers Association International (BOMA), however, objected to requiring building owners to provide anchor points, stating that window cleaners were generally able to find supports on which to tie off (Docket S–041, Tr. 9/14/90 p. 1443). BOMA did agree that new buildings completed two to five years after the effective date of the final rule should be equipped with anchor points (Docket S–041, Ex. 75).

IWCA and BOMA participated on the ANSI committee that developed the new national consensus standard addressing safety in window cleaning operations discussed earlier (ANSI I–14.1–2001—Window Cleaning Safety) (Docket S–029, Ex. 1–13). The ANSI standard directs building owners to provide, identify, certify, inspect annually and maintain anchorages for window washing activities. The standard also states that its provisions should be implemented within five years of publication of the standard, which was October 25, 2001 (ANSI I–14.1–2001, Appendix A, section b).

OSHA believes that anchorage points are necessary to ensure that scaffolding and other equipment can be safely tied back for any type of suspended work, not just window cleaning. This will prevent an employee from being injured or killed due to sudden movement of the scaffold. The ideal solution is for anchorages to be installed and maintained as part of the regular schedule for renovating and inspecting commercial buildings (e.g., rooftops). However, OSHA recognizes that many buildings may not currently have anchorages installed. Accordingly, the Agency seeks information on the following questions:

40. How many or what percentage of buildings are already equipped with anchorages to secure scaffolds, personal fall protection systems and controlled descent devices? What types of anchorages are present? Are there

specific types of buildings that do not generally have anchorages installed? Please explain.

41. Where anchorages are present, are they available for use with all suspended work or only for window cleaning? Are building owners inspecting and maintaining the anchorages? Please explain. What coordination takes place between building owners and employers who need anchorages for their employees? Can employers consult with building owners and install their own anchorages on buildings to protect their employees?

42. How should OSHA ensure that needed anchorage points are present and adequately maintained on buildings where suspended work is performed? Should OSHA require employers to obtain information from the building owner about available anchorages that have been tested, inspected, and maintained consistent with this subpart? Should OSHA require employers to prohibit employees from doing any suspended work until they receive assurance from the building owner that such anchorages are present? Please explain.

43. How frequently are the exteriors of commercial buildings such as rooftops renovated?

44. What would be a reasonable phase-in time or delayed effective date for ensuring that employees involved with suspended work are protected by anchorages that comply with subpart D? Should this timeframe be different for newly constructed buildings than for existing buildings? Please explain.

45. What are the estimated per building costs to install, inspect and maintain anchors for suspended work? Please explain how the estimated costs were derived.

#### *B. Subpart I—Personal Protective Equipment for Fall Protection*

##### 1. General Fall Protection Requirement

The proposal for subpart I sets forth design and performance criteria for personal fall protection equipment generally as well as for specific types of equipment (§§ 1910.128–131, 55 FR 13435–38). Proposed § 1910.128(a)(1) stated that these criteria would apply where personal fall protection is required by or referenced in another standard (e.g., § 1910.67 Vehicle-mounted elevating and platform; § 1910.179 Overhead and gantry cranes; § 1910.128(a)(1), 55 FR 13425).

Questions were raised about whether the language in paragraph (a)(1) of proposed § 1910.128 was intended to supersede the general requirement in subpart I for employers to provide

personal protective equipment, including personal fall protection systems, to their employees “whenever it is necessary by reason of hazards of processes or environment \* \* \* encountered in a manner capable of causing injury or impairment in function” (§ 1910.132(a)(1)).

OSHA has cited § 1910.132(a)(1) to enforce the use of personal fall protection equipment. This enforcement action has been upheld by the Occupational Safety and Health Review Commission. See, e.g., *Secretary of Labor v. Peavey Co.*, 16 O.S.H. Cas. (BNA) 2022 (Rev. Comm’n 1994); *Secretary of Labor v. Hackney*, 16 O.S.H. Cas. (BNA) 1806 (Rev. Comm’n. 1994). In addition, OSHA has applied the general duty clause, section 5(a)(1) of the Act, to enforce the use of personal fall protection where appropriate.

OSHA did not intend for § 1910.128 to supersede § 1910.132(a)(1) in any way. The Agency also did not intend for proposed § 1910.128 to supersede the fall protection provisions in other standards, requiring employers to use a different type of fall protection than those standards specify; for example, to require employers to use personal fall arrest systems when the standard requires guardrails. Instead, OSHA’s intention was to tell employers that if a standard specifies or refers to a particular type of personal fall protection equipment, that equipment would now have to meet the design and performance criteria of subpart I.

OSHA is considering ways to resolve any confusion the proposed language may have inadvertently created. For example, OSHA is considering adding language to subpart I to emphasize that § 1910.128’s general requirement for employers to provide personal protective equipment to protect employees against hazards includes protection against fall hazards. This is the approach used in the other specific PPE standards in subpart I. The standards on eye, face, head, respiratory and foot protection all contain language requiring their use when applicable hazards are present (§ 1910.133(a)(1), § 1910.134(a)(1), § 1910.135(a)(1), § 1910.136(a)(1)). A provision addressing fall protection, for instance, could require its use when applicable fall hazards are present, or, more specifically, when employees are exposed to fall hazards of 4 feet (1.2m) or more.

As an alternative, OSHA is considering adding language to subpart D (§ 1910.22, General requirements) that reinforces the employer’s duty to provide employees with fall protection. Such a provision could cover all types



of fall protection, not just personal fall protection systems.

OSHA solicits comment on the following issues:

46. In your establishment and/or industry, when and in what situations are employees provided with fall protection? Is fall protection provided for working conditions and activities not covered by a specific OSHA standard? Please explain.

47. In your establishment and/or industry, to what extent is the fall protection provided already consistent with proposed subparts D and I? To the extent that fall protection is not consistent with the proposals, please explain whether and why you would have any difficulty coming into compliance. Please address any technological and/or economic obstacles that may be involved.

48. In your establishment and/or industry, how many or what percentage of employees require fall protection on a regular basis? How much of their work requires them to have fall protection? Please explain.

49. Should OSHA add language to Subpart I reinforcing employers' current obligation to provide fall protection whenever employees are exposed to any fall hazard of 4 feet (1.2 m) or more? Please explain.

## 2. Body Belts for Fall Arrest

In the proposal for subpart I, OSHA proposed to allow the use of body belts for fall arrest as long as the maximum arresting force on the falling employee is limited to 900 pounds (4 kN) (§ 1910.129, 55 FR 13437). However, during the 1990 public hearings, OSHA was made aware of technological improvements in personal fall arrest equipment and of an industry trend away from the use of body belts for fall arrest (Docket S-041, Tr. 9/11/90 pp. 203-9, 240-41; Tr. 9/17/90 p. 1716). A number of fall protection experts consider body belts to be less protective than full body harnesses when arresting a fall and during post-fall suspension (Docket S-057, Exs. 3-31B; Docket S-041, Tr. 9/11/90 pp. 218-19, 230-31). Studies show that body belts can cause significant injury when arresting a fall and may result in injury during post-fall suspension (Docket S-057; Exs. 2-14, 2-24, 2-25).

OSHA and other Federal standards promulgated after the subpart I proposal was published have prohibited or phased out the use of body belts for fall arrest (§ 1926.502, Fall Protection in the construction industry; 49 CFR 214.7 and 49 CFR 214.105, Federal Railroad Administration, Railroad Workplace Safety). OSHA's Fall Protection

standard for the construction industry, finalized in 1994, prohibited the use of body belts for fall arrest after December 31, 1998. In the preamble to that rule, OSHA said evidence in the record (Docket S-206, Exs. 3-7, 3-9, 3-10) as well as the record for the Powered Platforms for Building Maintenance rulemaking (Docket S-700A, Exs. 11-3, 11-4, 11-5, 11-6; Tr. 2/21/86 p. 42) indicated that the concentration of the maximum arresting forces on the body, and the subsequent pressure from post-fall suspension, make body belts unsuitable for fall arrest purposes (59 FR 40672). OSHA also stated that “\* \* \* the evidence in the record clearly demonstrates that employees who fall while wearing a body belt are not afforded the level of protection they would be if the fall occurred while the employee was wearing a full body harness” (59 FR 40703).

Last year the Federal Railroad Administration (FRA) issued an interim final rule prohibiting the use of body belts for fall arrest (49 CFR 214.7 and 49 CFR 214.105)(67 FR 1903, January 15, 2002). In the preamble to the rule, the FRA stated that “it is now obvious that a formerly permitted use of body belts in fall arrest systems presents an undue hazard to the user”.

A 1992 ANSI national consensus standard on safety requirements for personal fall arrest systems declined to address the use of body belts for fall arrest (ANSI Z359.1-1992 (R1999)—Safety requirements for Personal Fall Arrest Systems, Subsystems and Components)(Docket S-029, Ex. 1-12).

While subpart Q, Welding, Cutting and Brazing, currently allows the use of body belts for fall arrest (§ 1910.252), OSHA believes it may be appropriate to prohibit body belts for fall arrest during welding, cutting and brazing operations.

In light of the recent information and regulatory action since proposed subpart I was published, OSHA is considering prohibiting the use of body belts as a personal fall arrest system and only permitting their use as part of a tether (restraint) or positioning system. The body of recent evidence indicates that using body belts for fall arrest may injure employees where strong fall arrest forces are involved, and that body harnesses are safer for employees. OSHA is requesting comment on this issue. OSHA also is requesting comment about whether there are certain unique situations in which body belts should continue to be allowed to be used for fall arrest, and whether it is appropriate to prohibit body belts for fall arrest during welding, cutting and brazing operations.

50. To what extent are body belts used in a personal fall arrest system in your establishment and/or industry? What has been the safety experience in your establishment and/or industry using body belts?

51. To what extent are body harnesses and other restraints being used in place of body belts in your establishment and/or industry? What types of harnesses and restraints are being used? What has been the safety experience in your establishment and/or industry using those types of equipment? Please provide data and comment on the extent to which body harnesses prevent death or injury or reduce the severity of injury.

52. In welding, cutting and brazing operations at your establishment and/or in your industry, what types of personal fall protection are being used? Are body belts being used for fall arrest in those operations? What has been the safety experience in your establishment and/or industry using those types of fall protection?

53. Should OSHA prohibit the use of body belts as part of a personal fall arrest system? Please explain. For how many or what percentage of employees would you need to replace body belts with body harnesses in your establishment or industry?

54. Are there unique situations or work activities where body belts are necessary or preferable to body harnesses, and provide the degree of safety needed against fall hazards? Please provide data and information to support your comments.

55. What are the differences in purchase price, maintenance costs and useful life, if any, between body belts and body harnesses? Please provide cost estimates and an explanation of how those were derived. To what extent, if any, does the use of body harnesses in lieu of body belts affect productivity?

56. To what extent would you and employers in your industry incur significant costs switching from body belts to body harnesses or other types of personal fall arrest systems? Please provide detailed information about the types of costs that would be incurred and an explanation of how those costs were derived.

## 3. Additional Proposed Amendments to General Industry Standards

In the proposal for subpart D, OSHA proposed to update fall protection provisions in several general industry standards so they would meet the proposed design and performance criteria for personal fall protection in subpart I (§ 1910.67, Vehicle-mounted elevating and rotating work platforms;

§ 1910.261, Pulp, paper and paperboard mills; § 1910.268, Telecommunications). The purpose of the proposed amendments was to ensure that all fall protection systems employers provided would meet appropriate standards for performance and strength. OSHA had found that many of the standards did not have design and performance criteria for the fall protection, had outdated criteria or had criteria that allowed the use of body belts for fall arrest.

After the proposal for subpart I was published, OSHA was made aware of other general industry standards where fall hazards were not specifically addressed, where fall protection criteria appear to conflict with proposed subpart I, or where body belts appeared to be permitted for fall arrest. The Powered Industrial Trucks standard, for example, does not include fall protection requirements for employees working on elevated platforms even though those employees are clearly exposed to a fall hazard (§ 1910.178). OSHA seeks comment on the following issues:

57. In your establishment and/or industry, to what extent is fall protection provided for employees working on elevated platforms of powered industrial trucks? What types of fall protection are provided? What has been the safety experience in your establishment and/or industry using those types of fall protection?

58. In welding, cutting and brazing operations at your establishment and/or in your industry, what types of personal fall protection are being used? Are body belts being used for fall arrest in those operations? What has been the safety experience in your establishment and/or industry using those types of fall protection?

59. Should OSHA change the personal fall protection requirements in all of its general industry standards so they meet the personal fall protection requirements in proposed subpart I? Please explain.

### C. Other Issues

#### 1. New and Updated National Consensus Standards

Many employers as well as OSHA use the latest versions of national consensus standards for guidance and as references in creating safe workplaces. Indeed, § 6(b)(8) of the Act requires that OSHA whenever the Agency issues a standard that differs substantially from an existing consensus standard it must publish a statement of reasons why the OSHA standard as adopted will better effectuate the purposes of the Act than

the consensus standard (29 U.S.C. 655(b)(8)).

In proposed § 1910.23, OSHA said that ladders employers used would be considered to be in compliance with the standard if they were designed in accordance with specific 1982 ANSI standards for ladders (ANSI A14.1–1982–American National Standard for Ladders-Wood-Safety Requirements; ANSI A14.2–1982–American National Standard for Ladders-Portable Metal-Safety Requirements; ANSI A14.5–1982–American National Standard for Ladders-Portable Reinforced Plastics-Safety Requirements)(§ 1910.23(c)(2), 55 FR 13398). Since the proposal for subpart D was published, these ANSI standards have been amended or reaffirmed (ANSI A14.1–2000, ANSI A14.2–2000, ANSI A14.5–2000). OSHA is adding these updated standards to the rulemaking record and is considering revising proposed § 1910.23(c)(2) to incorporate by reference the updated ANSI standards. OSHA requests comment on incorporating the latest ANSI standards in § 1910.23(c)(2).

In addition, a number of other national consensus standards relating to fall protection and fall protection systems have been updated and new ones have been developed (e.g., ANSI/IWCA I–14.1–2001–Window Cleaning Safety) since proposed subpart D was published. These consensus standards cover a wide range of issues involved in these rulemakings and, in general, represent industry best practices in protecting employees from fall hazards. In addition, many provide detailed explanations on the rationale behind their requirements. OSHA requests comment about how the Agency can make best use of these consensus standards in developing final standards for subparts D and I.

OSHA is adding the following national consensus standards to the rulemaking record on subparts D and I:

ANSI A10.8–2001—Safety Requirements for Scaffolding—American National Standard for Construction and Demolition Operations. (Docket S–029; Ex. 1–1),

ANSI A14.1–2000—American National Standard for Ladders—Wood—Safety Requirements. (Docket S–029; Ex. 1–2),

ANSI A14.2 2000—American National Standard for Ladders—Portable Metal—Safety Requirements. (Docket S–029; Ex. 1–3),

ANSI A14.3–1992—American National Standard for Ladders—Fixed—Safety Requirements. (Docket S–029; Ex. 1–4),

ANSI A14.4–2002—American National Standard—Safety

Requirements for Job-Made Wooden Ladders. (Docket S–029; Ex. 1–5),

ANSI A14.5–2000—American National Standard for Ladders—Portable Reinforced Plastic—Safety Requirements. (Docket S–029; Ex. 1–6),

ANSI A14.7–2000—American National Standard for Mobile Ladder Stands and Mobile Ladder Stand Platforms. (Docket S–029; Ex. 1–7),

ANSI A14.10–2000—American National Standard for Ladders—Portable Special Duty Ladders. (Docket S–029; Ex. 1–8),

ANSI A92.3–1990—American National Standard for Manually Propelled Elevating Aerial Platforms. (Docket S–029; Ex. 1–9),

ANSI A1264.1–1995 (R2002)—American National Standard—Safety Requirements for Workplace Floors and Wall Openings, Stairs and Railing Systems. (Docket S–029; Ex. 1–10),

ANSI A1264.2–2001—American National Standard—Standard for the Provision of Slip Resistance on Walking/Working Surfaces. (Docket S–029; Ex. 1–11),

ANSI/IWCA I–14.1–2001—Window Cleaning Safety. (Docket S–029; Ex. 1–13)

ANSI Z359.1–1992 (R1999)—Safety Requirements for Personal Fall Arrest Systems, Subsystems and Components. (Docket S–029; Ex. 1–12),

ASME B56.1–2000—Safety Standard for Low Lift and High Lift Trucks. (Docket S–029; Ex. 1–14), and

ASME C478–97—Standard Specification for Precast Reinforced Concrete Manhole Sections. (Docket S–029; Ex. 1–15).

OSHA is also requesting comment about other national consensus standards that the Agency should consider adding to the record in these rulemakings.

#### 2. Incorporation of Other Rulemaking Dockets

As discussed above, OSHA believes that information in other OSHA rulemaking records is relevant to the rulemakings on subparts D and I. Many commenters also have drawn upon data and information in other OSHA dockets. OSHA has identified the following rulemaking dockets that it intends to incorporate into the rulemaking records for subparts D and I:

- Docket S–041 Walking and Working Surfaces (proposed April 10, 1990, 55 FR 13360),

- Docket S–057 Personal Protective Equipment (Fall Protection) (proposed April 10, 1990, 55 FR 13360),

- Docket S–045 Personal Protective Equipment for Shipyard Employment (proposed November 29, 1988, 53 FR

48092, final rule published May 24, 1996, 61 FR 26322),

- Docket S-700A Powered Platforms for Building Maintenance (proposed January 22, 1985, 50 FR 2890, final rule published July 28, 1989, 54 FR 31408),

- Docket S-206 Fall Protection in the Construction Industry (proposed November 25, 1986, 51 FR 42718, final rule published August 9, 1994, 59 FR 40672),

- Docket S-015 Electric Power Generation, Transmission and Distribution (proposed January 31, 1989, 54 FR 4974, final rule published, January 31, 1994, 59 FR 4320), and

- Docket S-775 Safety Standards for Steel Erection (proposed January 26, 1988, 53 FR 2048, final rule published January 18, 2001 66 FR 5196).

The Agency is requesting comment about other OSHA rulemaking records that should be incorporated by reference into the record for these rulemakings.

#### D. Updating Economic Analysis and Small Business Impacts

In order to develop final standards for subparts D and I, OSHA will need to update and revise its economic analysis. The questions above and those following are designed to aid OSHA in updating its analysis of the provisions of the proposed rules and to assist OSHA in evaluating possible revisions or amendments. The economic analysis for the proposals on subparts D and I certified that the proposed rules would not result in a significant impact on a substantial number of small entities.

Under the Regulatory Flexibility Act (5 U.S.C. 601 *et seq.*), OSHA is required to assess the impact of proposed and final rules on small entities. OSHA requests that members of the small business community, or other parties familiar with regulation of small business, provide comment on whether the proposed revisions to subparts D and I would have a significant impact on a significant number of small entities.

60. How many and what kinds of small businesses or other small entities in your industry could be affected by revising the fall protection provisions in subparts D and I? Describe any such effects. Where possible, please provide detailed descriptions of the size and scope of operation for affected small entities and the likely technical, economic and safety impacts for those entities.

61. Are there special issues that make control of fall hazards more difficult in small firms?

62. Are there any reasons that the benefits of reducing exposure to fall hazards might be different in small

firms than in larger firms? With regard to potential impacts on small firms, please describe specific concerns that should be addressed. Please describe alternatives that might serve to minimize these impacts while meeting the requirements of the OSH Act.

Since the proposals were published, the Small Business Regulatory Enforcement Fairness Act of 1996 (SBREFA) (5 U.S.C. 609(b)) went into effect. SBREFA requires that OSHA proposed rules that may have significant impacts on small entities be reviewed by Small Business Advocacy Panels prior to being published. OSHA requests comments about whether the proposed revisions for subparts D and I will have a significant effect on a substantial number of small entities.

#### V. Authority and Signature

This document was prepared under the direction of John L. Henshaw, Assistant Secretary of Labor for Occupational Safety and Health, U.S. Department of Labor, 200 Constitution Avenue, NW., Washington, DC 20210. It is issued under sections 4, 6 and 8 of the Occupational Safety and Health Act of 1970 (29 U.S.C. 653, 655, 657), Secretary of Labor's Order No. 5-2002 (67 FR 65008) and 29 CFR part 1911.

Signed at Washington, DC, this 25th day of April, 2003.

**John L. Henshaw,**

*Assistant Secretary of Labor.*

#### Appendix—1990 Proposed Standard and Appendices

OSHA has included the regulatory text and appendices from the April 10, 1990 proposed rule (55 FR 13396) as an appendix to this limited reopening notice. This appendix may serve as an aid for stakeholders who respond to questions in this limited reopening regarding issues referencing the 1990 proposed rule.

#### PART 1910—OCCUPATIONAL SAFETY AND HEALTH STANDARDS

1. The authority citation for subpart D of part 1910 is proposed to be revised as follows:

**Authority:** Secs. 4, 6 and 8 of the Occupational Safety and Health Act of 1970 (29 U.S.C. 653, 655, 657), Secretary of Labor's Order No. 12-71 (36 FR 8754), 8-76 (41 FR 25059), and 9-83 (48 FR 35736) or 1-90 (55 FR 9033), as applicable. Subpart D is also issued under 29 CFR part 1911.

2. In subpart D, §§ 1910.21 through .32 would be revised, and Appendices A, B, and C would be added to read as follows:

#### Subpart D—Walking-Working Surfaces

Sec.

1910.21 Scope, application and definitions.

1910.22 General requirements.

1910.23 Ladders.

1910.24 Step bolts and manhole steps.

1910.25 Stairs.

1910.26 Ramps and bridging devices.

1910.27 Work surfaces.

1910.28 Fall protection systems.

1910.29 Wall openings.

1910.30 Scaffolds.

1910.31 Mobile elevating work platforms, mobile ladder stands and powered industrial truck platforms.

1910.32 Special surfaces.

Appendix A—Compliance Guidelines.

Appendix B—National Consensus Standards.

Appendix C—References for Further Information.

#### Subpart D—Walking and Working Surfaces

##### § 1910.21 Scope, application and definitions.

(a) *Scope and application.* This subpart covers all walking and working surfaces that are used by employees, except as follows:

(1) This subpart does not apply to surfaces that are an integral part of self-propelled, motorized mobile equipment, other than platforms hoisted or lifted by powered industrial lift trucks which are covered by paragraph (e) of § 1910.31.

(2) This subpart does not apply to powered exterior building maintenance platforms covered in subpart F of Part 1910.

(3) This subpart does not cover fall hazards from the exposed perimeters of entertainment stage, rail station platforms.

(b) *Definitions.*

“Allowable unit stress” means the maximum stress allowed to be applied as specified by recognized national codes and standards such as the American Society of Testing and Materials (ASTM), and the National Fire Protection Association (NFPA).

“Alternating tread stairs” means a series of steps usually attached to a center support rail in an alternating manner so that a user of the stairs normally does not have both feet on the same level.

“Authorized person” means an employee who, due to the requirements of work duties, is authorized by the employer to be present in a particular work area.

“Boatswain's chair” means a single-point adjustable suspension scaffold consisting of a seat or sling designed to accommodate one employee in a sitting position.

“Body belt” (safety belt) means a strap with means for securing it around the waist or body and for attaching it to a lanyard, lifeline, or deceleration device.

“Body harness” means a design of straps which is secured about the employee in a manner so as to distribute the arresting forces over at least the thighs, shoulders, and pelvis, with provisions for attaching a lanyard, lifeline, or deceleration device.

“Bridging device” means a surface used to span the gap between a loading dock and a vehicle or between vehicles. It may be fixed or portable, adjustable, powered or unpowered. It may also be referred to as a car plate or dockboard.

“Combination ladder” means a portable ladder capable of being used as a stepladder or as a single or extension ladder. It may also

be capable of being used as a trestle ladder or a stairwell ladder. Its components may be used as single ladders.

“Design factor” means the ratio of the ultimate failure strength of a member or piece of material or equipment to the actual working stress or intended safe load.

“Designated area” means a space which has a perimeter barrier erected to warn employees when they approach an unprotected side or edge, and serves also to designate an area where work may be performed without additional fall protection. “Equivalent” means alternate designs, materials, or methods which the employer can demonstrate will provide an equal or greater degree of safety for employees than the method or item specified in the standard.

“Failure” means a load refusal, breakage, or separation of component parts. Load refusal is the point where the ultimate strength is exceeded.

“Fall” or “fall hazard” means the act or circumstances that could result in the possibility of slipping or tripping on or falling off a surface.

“Fixed ladder” means a ladder, including individual rung ladders, that is permanently attached to a structure, building, or equipment. It does not include ship’s stairs or manhole steps.

“Guardrail system” means a vertical barrier, normally consisting of, but not limited to, an assembly of top rails, midrails, and posts, erected to prevent employees from falling to lower levels.

“Handrail” means a rail used to provide employees a handhold for support.

“Hole” means an opening more than two inches (5.1 cm) in its least dimension in a floor, roof, or other surface.

“Individual rung ladder” means a ladder consisting of rungs individually attached to a structure, building, or piece of equipment. It does not include manhole steps installed in manholes.

“Ladder” means a device typically used to gain access to a different elevation consisting of two or more structural members crossed by rungs, steps, or cleats.

“Ladder cage” means a barrier surrounding or nearly surrounding the climbing area of a ladder. It fastens to the ladder’s side rails, to one side rail, or to other structures.

“Ladder safety device” means a support system which will stop or limit the speed of an employee’s fall from a ladder.

“Lean-to scaffold” means a supported scaffold which is kept erect by tilting it toward and resting it against a building or structure.

“Lower level” means those areas to which an employee could fall. Such areas include ground levels, floors, roofs, ramps, runways, excavations, pits, tanks, materials, water, equipment, and similar surfaces.

“Manhole” means an access through which an employee gains entry to a work area or to equipment below a surface or behind a vertical partition such as a vessel wall.

“Manhole steps” means a series of steps individually attached or set into the walls of a manhole structure. They are not considered to be an individual rung ladder.

“Manually propelled elevating work platform” means a vertically adjustable work

platform which may be towed, skidded or manually moved horizontally or the base structure may remain stationary.

“Manway” means an opening through which employees access vessels and equipment.

“Maximum intended load” means the total load of all employees, equipment, tools, materials, transmitted loads, wind loads and other loads reasonably anticipated to be applied.

“Midrail” means the rail located approximately midway between the top rail and the toeboard or work surface of a guardrail system.

“Mobile elevating work platform” means a portable platform that can be elevated and moved about on wheels or casters.

“Mobile ladder stand” means a mobile fixed-size self-supporting ladder consisting of a wide flat tread ladder in the form of stairs. The assembly may include handrails, guardrails and toeboards. It may also be referred to as a ladder stand.

“Mobile scaffold” means a portable caster or wheel-mounted supported scaffold. It may also be referred to as a mobile work platform.

“Platform” means a work surface elevated above the surrounding work area.

“Platform unit” means the individual wood planks, fabricated planks, fabricated decks, and fabricated platforms such as ladder-type and light metal-type, which comprise the platforms and walkways of a scaffold.

“Portable ladder” means a ladder that can readily be moved or carried, usually consisting of side rails joined at intervals by steps, rungs, cleats, or rear braces.

“Qualified climber” means an employee who, by virtue of physical capabilities, training, work experience and job assignment, is authorized by the employer to routinely climb fixed ladders, step bolts or similar climbing devices attached to structures.

“Qualified person” means an person designated by the employer who is knowledgeable about and familiar with all relevant manufacturers’ specifications and recommendations; is capable of identifying existing or potential hazards in specific surroundings or working conditions which may be hazardous or dangerous to employees; and has been trained for the specific task assigned. When work is to be supervised by a qualified person, the qualified person shall have the necessary authority to carry out the assigned work responsibilities.

“Ramp” means an inclined surface between different elevations for the passage of employees, vehicles, or both.

“Riser” means the upright member of a step situated at the back of a lower tread and near the leading edge of the next higher tread.

“Safety net” means a non-rigid barrier supported in such a manner as to catch employees who have fallen off a work surface and bring them to a stop before contacting surfaces or structures below the net which might otherwise injure them.

“Scaffold” means any temporary elevated or suspended platform, and its supporting structure, used for supporting employees or

materials or both, except this term does not include crane or derrick suspended personnel platforms.

“Ship’s stairs” means a stairway equipped with treads and stair rails with a slope greater than 50 degrees from the horizontal. It is sometimes referred to as a “ship’s ladder.”

“Shore scaffold” means a supported scaffold which is kept erect by placing it against a building or structure and holding it in place with props.

“Single-point adjustable suspension scaffold” means a suspension scaffold consisting of a platform suspended by one rope from an overhead support and equipped with means to permit the movement of the platform to desired work levels.

“Slip-resistant surface” means a surface that is capable of resisting the sliding motion on the contact surface of an object or an employee’s shoe or foot.

“Spiral stairway” means a stairway having a spiral structure attached to a supporting column.

“Stair” means a series of steps used to ascend or descend between levels, and having four or more risers installed at an angle equal to or less than 50 degrees from the horizontal.

“Stair rail” or “stair rail system” means a vertical barrier erected along the open-side of a stairway to prevent employees from falling to lower levels. The top surface of a stair rail system may also be a handrail.

“Step” means any combination of risers and treads which may be part of a stair.

“Step ladder” means a self-supporting portable ladder, non-adjustable in length, with flat steps and a hinged back.

“Step-bolt” means a bolt or rung attached at intervals along a structural member and used for foot placement during climbing or standing. Step bolts may also be called “pole steps.”

“Structurally supported” means supported by structural components such as pillars, piers, lintels, beams and joists. It does not include slabs or floors placed on a grade.

“Tieback” means an attachment from a structural member to a supporting device.

“Toeboard” means a low protective barrier placed to prevent the fall of materials to a lower level, or when used without a guardrail, to prevent an employee’s feet from slipping over the edge of a surface.

“Tread” means the horizontal member of a step.

“Two-point suspension scaffold” (swing stage) means a suspension scaffold consisting of a platform supported by hangers (stirrups) suspended by two ropes from overhead supports and equipped with means to permit the raising and lowering of the platform to desired work levels.

“Ultimate failure” means the collapse of the structure or, where applicable, a component thereof.

“Unprotected sides and edges” means any side or edge of a surface, except at entrances to points of access, where there is no wall or guardrail system.

“Walking and working surface” means any surface, within the scope of this standard, on which employees perform or gain access to their job duties or upon which employees are required or allowed to walk or work while performing assigned tasks.

“Wall opening” means an opening at least 30 inches (76 cm) high and 18 inches (46 cm) wide in any wall or partition through which employees can fall to a lower level.

**§ 1910.22 General requirements.**

(a) *Surface conditions and clearances.* (1) Surfaces shall be designed, constructed and maintained free of recognized hazards that can result in death or serious injury to employees.

(2) When surfaces cannot be maintained free of hazards, such as snow, ice or oil, that can result in death or serious injury to employees, employees shall be provided with a means to avoid or minimize their exposure to them.

(3) A minimum free clearance of 18 inches (46 cm) shall be provided for employee passage around or between obstructions.

(4) Manways or manholes built on or after (insert date one year after effective date of the final rule in the Federal Register) leading to sewers, non-pressurized tanks, atmospheric vessels and enclosures, and other confined spaces shall be at least 24 inches (61 cm) in diameter.

(b) *Application of loads.* (1) All surfaces shall be designed, constructed and maintained to support their maximum intended load. The maximum intended load shall not be exceeded.

(2) The employer shall ensure that employees involved in warehousing or storage activities know the intended load limits for structurally supported surfaces in the areas where they work.

(c) *Access and egress.* The employer shall ensure that employees are provided with and use a safe means of access to, and egress from, one surface to another.

(d) *Inspection, maintenance, and repair.*

(1) The employer shall ensure through regular and periodic inspection and maintenance that walking and working surfaces are in safe condition for employee use.

(2) The employer shall ensure that all hazardous conditions which are discovered are corrected, repaired, or temporarily guarded to prevent employee use. Repairs shall be made in a manner that will restore the walking and working surface to a safe condition for employee use.

(3) Only qualified persons shall be permitted to inspect, maintain or repair

walking and working surfaces except for the incidental cleanup of non-toxic materials.

**§ 1910.23 Ladders.**

(a) *Scope and application.* This section covers all ladders, except that:

(1) This section does not apply to ladders which are used only for firefighting or rescue operations, or to those ladders which form an integral part of machinery; and

(2) Fixed ladders that are used only by qualified climbers, as defined in § 1910.32(b)(5), are not required to be equipped with ladder safety devices, wells or cages, provided the following requirements are met:

(i) The installation and maintenance of the ladder safety devices, wells or cages present a greater hazard than having a qualified climber use a fixed ladder without this protection.

(ii) The ladder is climbed two or fewer times per year.

(b) *General requirements.* (1) Employers shall ensure that all employees who use ladders with a working height of six feet (1.82 m) or more receive the necessary training, such as how to inspect ladders, and use such ladders properly.

(2) Ladders shall be used only for the purposes for which they were designed.

(3) Non-self-supporting ladders shall be used at an angle such that the horizontal distance from the top support to the foot of the ladder is approximately one-fourth of the working length of the ladder (the distance along the ladder between the foot and top support).

(4) When ladders are used for access to an upper landing surface, the ladder siderails shall extend at least three feet (.9 m) above the upper landing surface to which the ladder is used to gain access; or, when such an extension is not possible because of the ladder’s length, the ladder shall be secured at the top and a grasping device, such as a grabrail, shall be provided to assist employees in mounting and dismounting the ladder.

(5) Ladders shall be used only on stable and level surfaces unless secured to prevent their accidental displacement. Non-self-supporting ladders shall not be used on slippery surfaces unless secured or provided with slip-resistant feet to prevent accidental displacement.

(6) Single rail ladders shall not be used.

(7) Ladders shall not be moved, shifted or extended while occupied by employees.

(8) Ladders placed in any location where they can be displaced by other activities or traffic, such as in passageways, doorways, or driveways, shall be secured to prevent accidental displacement, or a barricade shall be used to keep the activities or traffic away from the ladder.

(9) Ladders with structural or other defects shall be immediately tagged with a danger tag reading “Out of Service,” “Do Not Use,” or similar legend in accordance with § 1910.145, and shall be withdrawn from service until repaired.

(10) All ladder repairs shall be made by a qualified person trained and familiar with the design and the proper procedures for repairing defective components.

(11) Ladders shall be inspected for visible defects prior to the first use each workshift, and after any occurrence which could affect their safe use.

(12) The top of a non-self-supporting ladder shall be placed with the two rails supported unless it is equipped with a single support attachment.

(13) Emergency escape ladders shall comply with all applicable requirements of this section except those requiring fall protection systems.

(14) The top of a stepladder shall not be used as a step.

(c) *Design, construction, maintenance and inspection.*

(1) Portable ladders shall be capable of supporting, without ultimate failure, the following loads:

(i) Each non-self-supporting ladder: At least four times the maximum intended load applied or transmitted to the ladder in a downward and vertical direction when the ladder is placed at a 75½ degree angle from the horizontal.

(ii) Each self-supporting ladder: At least four times the maximum intended load in a fully opened position on a level surface.

(2) Ladders designed in accordance with ANSI A14.1–1982, ANSI A14.2–1982, and ANSI A14.5–1982 are deemed to be in compliance with the requirements of paragraph (c)(1) of this section for the type of ladder to be used. The working loads corresponding to the duty ratings of portable ladders that pass the applicable ANSI test requirements shall be as follows:

Duty rating	Ladder type	(pounds)	Working load (Kg)
Extra heavy duty .....	IA	300	136.2
Heavy duty .....	I	250	113.5
Medium duty .....	II	225	102.2
Light duty .....	III	200	90.8

(3) The design of combination ladders shall be such that the ladder will be capable of meeting the requirements in paragraphs (c)(1) or (c)(2) of this section for stepladders when in the stepladder position, and for extension ladders when in the extension ladder position.

(4) The maximum intended load used for the design of portable ladders shall be at least 200 pounds (90.6 Kg).

(5) The combined weight of the employee using the portable ladder and any tools and supplies carried by the employee shall not exceed the maximum intended load of the ladder.

(6) Fixed ladders shall be capable of supporting at least two loads of at least 250 pounds (114 kg) each, concentrated between any two consecutive attachments, plus anticipated loads caused by ice buildup, winds, rigging, and impact loads resulting from the use of ladder safety devices. The number and position of additional concentrated loads of 250 pounds (114 kg)

each, determined from anticipated usage of the ladder, shall also be included in determining the capabilities of fixed ladders. Each step or rung shall be capable of supporting at least a single concentrated load of 250 pounds (114 kg) applied in the middle of the step or rung.

(7) Ladder rungs and steps shall be parallel, level, and uniformly spaced when the ladder is in position for use.

(8) Ladder rungs and steps shall be spaced not less than six inches (15 cm) apart, nor more than 12 inches (31 cm) apart as measured along the ladder siderails.

*Exception to paragraph (c)(8) of this section:* End frames of scaffolds and ladders in elevator shafts shall have rungs and steps spaced not less than six inches (15 cm) apart, nor more than 16-1/2 inches (41 cm) apart, as measured along the ladder siderails.

(9) Ladder rungs and steps shall have a minimum clear width of 16 inches (41 cm) for individual-rung and fixed ladders, 12 inches (30 cm) for portable metal ladders and portable reinforced plastic ladders, and 11-1/2 inches (29 cm) for portable wood ladders, as measured between the ladder siderails.

*Exception to paragraph (c)(9) of this section:* Narrow rungs, which are not designed to be stepped on, on the tapered ends of window washer ladders, fruit pickers' ladders, and similar ladders are exempt from the minimum rung width requirement.

(10) Wood ladders shall not be coated with any opaque covering, except for identification or warning labels which may be placed on one face only of a side rail.

(11) Metal ladders shall be protected against corrosion.

(12) The minimum toe clearance between the center line of ladder rungs and steps and any obstructions behind the ladder shall be seven inches (18 cm).

*Exception to paragraph (c)(12) of this section:* Toe clearances of no less than four and one-half inches (11.4 cm) are acceptable when a specific work operation renders a seven inch (17.8 cm) clearance infeasible.

(13) The minimum perpendicular clearance between the center line of fixed ladder rungs and steps and any obstruction on the climbing side of the ladder shall be 30 inches (76 cm).

*Exception to paragraph (c)(13) of this section:* When unavoidable obstructions are encountered, the minimum perpendicular clearance between the centerline of fixed ladder rungs and steps and the obstruction on the climbing side of the ladder may be reduced to 24 inches (61 cm) provided that a deflection device is installed to guide employees around the obstruction.

(14) Fixed ladders shall be equipped with personal fall protection systems in accordance with subpart I of this Part, or with cages or wells, wherever the length of any climb on any fixed ladder exceeds 24 feet (7.3 m), or wherever the top of the ladder is at a distance greater than 24 feet (7.3 m) above lower levels.

(15) Cages and wells provided for fixed ladders shall be designed to permit easy access to or egress from the ladder which they enclose. The cages and wells shall be continuous throughout the length of the fixed

ladder except for access, egress and other transfer points. Cages and wells shall be designed and constructed to contain employees in the event of a fall, and to direct them to a lower landing.

(16) The length of continuous climb for any fixed ladder equipped only with a cage or well shall not exceed 50 feet (15.2 m). When ladder safety devices are also used with cages or wells, the length of continuous climb may exceed 50 feet (15.2 m).

(17) Fixed ladders with continuous lengths of climb greater than 150 feet (45.7 m) shall be provided with rest platforms at least every 150 feet (45.7 m). The rest platforms shall provide a horizontal surface of at least 18 inches by 24 inches (46 cm by 61 cm) and have at least the same strength as required for the fixed ladder.

(18) Except where portable ladders are used to access fixed ladders, ladders shall be offset with a landing platform between each ladder when two or more separate ladders are used to reach a work area. Landing platforms shall provide a horizontal surface of at least 24 inches by 30 inches (61 cm by 76 cm) and have at least the same strength as the ladders.

(19) Ladder surfaces shall be free of puncture or laceration hazards.

(20) Fixed individual rung ladders shall be constructed to prevent the employee's feet from sliding off the end.

(21) The distance from the centerline of fixed ladder grab bars to the nearest permanent object in back of the grab bars shall be no less than four inches (10 cm).

(22) A ladder that might contact uninsulated energized electrical equipment shall have nonconductive siderails.

(23) Ladders having a pitch in excess of 90 degrees from the horizontal shall not be permitted, except for fixed ladders used in conical sections of manholes.

(24) The step-across distance from the centerline of the steps or rungs of a fixed ladder to the nearest edge of the structure, building, or equipment accessed shall not exceed 12 inches (30 cm).

(25) Ladders and ladder sections, unless so designed, shall not be tied or fastened together to provide longer length. Ladders and ladder sections shall not have their length increased by other means unless specifically designed for the means employed.

(26) A metal spreader or locking device shall be provided on each stepladder or combination ladder when used in the stepladder mode to hold the front and back sections securely in an open position.

#### § 1910.24 Step bolts and manhole steps.

(a) *Scope and application.* This section covers step bolts and manhole steps used on structures such as, but not limited to, towers, stacks, conical manhole sections, and vaults. This section does not apply to individual rung ladders.

(b) *General requirements.* (1) Step bolts and manhole steps shall be continuous and spaced uniformly, not less than six inches (15 cm) nor more than 18 inches (46 cm) apart.

(2) The minimum clear step width of step bolts shall be four and one-half inches (14.4 cm). The minimum clear step width of manhole steps shall be 10 inches (25.4 cm).

(3) The minimum toe clearance for manhole steps shall be four inches (11.1 cm) from the point of embedment on the wall to the outside face of the step. The toe clearance in the center of the manhole step shall be a minimum of four and one-half inches (11.4 cm) measured to the outside face of the step.

(4) The minimum toe clearance for step bolts shall be seven inches (17.8 cm). Where obstructions cannot be avoided, toe clearances may be reduced to four and one-half inches (11.4 cm).

(5) Step bolts and manhole steps shall be designed to prevent the employee's foot from slipping or sliding off the end of the step bolt or manhole step.

(6) All manhole steps and step bolts installed after (*insert date 60 days after the effective date of the final rule in the Federal Register*) and used in corrosive environments, shall be constructed of, or coated with, a material that will retard corrosion of the step or bolt.

(7) All manhole steps installed on or after (*insert date 60 days after the effective date of the final rule in the Federal Register*) shall be provided with slip-resistant surfaces such as, but not limited to, corrugated, knurled, or dimpled surfaces.

(c) *Design, construction, maintenance, and inspection.* (1) *Step bolt design.* Each step bolt shall be capable of withstanding, without failure, at least four times the intended load to be applied to the bolt.

(2) Manhole steps installed before (*insert date 60 days after the effective date of the final rule in the Federal Register*) shall be capable of supporting their maximum intended load.

(3) *Design of manhole steps installed after (insert date 60 days after the effective date of the final rule in the Federal Register).* The employer shall ensure that manhole steps installed on or after (*insert date 60 days after the effective date of the final rule in the Federal Register*) shall meet the following requirements:

(i) The manhole steps shall be capable of withstanding and remaining solidly secured after being subjected to a separate application of a horizontal pull out load of 400 pounds (1780 N), and a vertical load of 800 pounds (3650 N).

(ii) The manhole steps shall be capable of sustaining the vertical test load without developing a permanent set greater than one-half inch (12.7 mm).

(iii) The loads shall be applied over a width of three and one-half inches (8.9 cm) centered on the step, and applied at a uniform rate until the required load is reached.

(iv) No cracking or fracture of the step nor spalling of the concrete shall be visible.

(4) *Maintenance and inspection.* Step bolts and manhole steps shall be maintained in a safe condition and visually inspected prior to each use.

(5) *Component replacement.* Step bolts which are bent greater than 15 degrees below the horizontal shall be removed and replaced with bolts that meet the requirements of this section. Manhole steps that are bent to such an extent as to reduce the step's projection from the wall to less than four inches (11.1 cm) shall be removed and replaced with a

step meeting the requirements of this section, or with a climbing device meeting the requirements of this subpart.

#### § 1910.25 Stairs.

(a) *Scope and application.* This section covers fixed stairs, spiral stairs, ship's stairs and alternating tread type stairs. It does not apply to stairs on mobile equipment; to articulated stairs that may be installed on floating roof tanks, waterfront dock facilities or access facilities to mobile equipment at angles which change with the rise and fall of the floating support or various heights of mobile equipment; or to stairs forming an integral part of machinery. It also does not apply to stairs used only for an emergency means of egress, which are covered by subpart E of this Part.

(b) *General requirements.* (1) Stairs with four or more risers shall be provided with at least one handrail. A stair rail system shall be provided on all unprotected sides or edges of stairways with a fall hazard of four feet (1.2 m) or more.

(2) Handrails and stair rails shall meet the applicable requirements in § 1910.28(c). Stair rail systems may also serve as handrails when properly installed.

(3) The sides and edges of stair landings with a fall hazard of four feet (1.2 m) or more, unless otherwise enclosed, shall be provided with guardrail systems meeting the requirements of § 1910.28.

(4) Stairs shall be capable of supporting, without failure, at least five times their maximum intended load.

(5) All stairs installed before (*insert date 60 days after the effective date of the final rule in the Federal Register*) shall have a minimum vertical clearance of six feet, eight inches (2.05 m). The vertical clearance for all stairs (except spiral stairs) installed on or after (*insert date 60 days after the effective date of the final rule in the Federal Register*) shall be a minimum of seven feet (2.1 m).

(6) Stairs shall be installed with uniform riser heights and tread depths between landings.

(c) *Fixed stairs.* (1) Fixed stairs shall be installed at angles up to 50 degrees from the horizontal.

(2) Riser heights on fixed stairs shall be from six and one-half inches to nine and one-half inches (16.5 to 24.1 cm). (3) Fixed stairs shall have a minimum width of 22 inches (55.9 cm) between vertical barriers.

(4) Fixed stairs with closed risers shall have a minimum stair tread depth of eight inches (20.3 cm).

(5) Fixed stairs with open risers shall have a minimum tread depth of six inches (15.2 cm).

(6) Stairway landings and platforms measured in the direction of travel shall be at least 22 inches (55.9 cm) wide, and not less than 30 inches (76 cm) in length.

(d) *Spiral stairways.* (1) The clear width of the stairs shall not be less than 26 inches (66 cm).

(2) The height of the riser shall not exceed nine and one-half inches (24.1 cm).

(3) The minimum headroom above spiral stairways shall be six feet, six inches (198 cm).

(4) Treads shall have a minimum depth of seven and one-half inches (19.1 cm) at a point 12 inches (30.5 cm) from the narrowest edge.

(5) All treads shall be identical.

(6) Where doors or gates open directly onto spiral stairways, landings shall be provided meeting the requirements of paragraph (c)(6) of this section.

(e) *Ship's stairs installed on or after (insert date 60 days after the effective date of the final rule in the Federal Register).*

(1) Ship's stairs shall be installed at a slope between 50 degrees and 70 degrees from the horizontal.

(2) Risers shall be open; treads shall be at least four inches (10 cm) in depth, 18 inches (46 cm) in width, and have a vertical rise between tread surfaces of six and one-half to 12 inches (16 to 30 cm).

(3) Handrails meeting the requirements of § 1910.28 shall be installed on both sides of ship's stairs.

(f) *Alternating tread type stairs.* (1) Alternating tread type stairs shall have a series of steps between 50 and 70 degrees from the horizontal.

(2) Handrails shall be provided on both sides of alternating tread type stairs.

(3) The width between handrails shall be from 17 to 24 inches (43 to 61 cm).

(4) Alternating tread type stairs shall be equipped with slip-resistant surfaces on the treads.

(5) The tread shall have a minimum depth of eight and one-half inches (22 cm).

(6) The tread shall be at least seven inches (18 cm) wide at the nosing.

(7) Landings or platforms shall meet the requirements in paragraph (c)(6) of this section.

#### § 1910.26 Ramps and bridging devices.

(a) *General requirements.* (1) Ramps and bridging devices shall be designed, constructed and maintained to support their maximum intended loads.

(2) Ramps and bridging devices used for the passage of vehicles shall be designed, constructed and maintained to prevent vehicles from running off the edge.

(3) There shall be a clearly designated and separated walkway for foot passage outside of the vehicle lane when ramps and bridging devices are used for the simultaneous passage of pedestrians and motorized vehicles except when pedestrians can precede or follow a vehicle at a safe distance.

(4) Ramps and bridging devices shall be secured to prevent their displacement while employees are on them. Vehicles, such as freight cars, onto which a ramp or bridging device has been placed, shall be prevented from moving, by such means as chocks or sand shoes, while the ramp or bridging device is being used by employees.

(5) A safe means of handling portable ramps and bridging devices, such as handholds or grab handles, shall be provided for employee use.

(6) Ramps and bridging devices constructed of two or more planks shall have the planks securely connected together to prevent displacement.

(b) *Specific requirements.* (1) *Fixed ramps.* (i) Each ramp used by employees that has a

ramp angle greater than 20 degrees from the horizontal shall be provided with handrails meeting the requirements of § 1910.28.

(ii) The employer shall assure that the angle of ramps used by employees does not exceed 30 degrees from the horizontal.

(iii) Ramps which have a fall hazard of four feet (1.2 m) or more shall be provided with a stair rail system or equivalent fall protection system meeting § 1910.28.

(2) *Portable or elevating ramps and bridging devices.* (i) When one or both ends of a portable or elevating ramp or bridging device are not secured to the vehicle or dock, there shall be an overlap of at least four inches (10.2 cm) onto the unattached surface or surfaces.

(ii) Fall protection systems are not required for ramps or bridging devices when they are being used exclusively for material handling operations with motorized equipment, when:

(a) Employees engaged in those operations are exposed to fall hazards less than 10 feet (3 m); and,

(b) Those employees have been trained to recognize and avoid the hazards involved with this work. This training shall consist of instructions in the proper placement and securing of the ramps and bridging devices, securing of vehicles, and the proper use of material-handling equipment.

#### § 1910.27 Work surfaces.

(a) *Scope and application.* (1) *Scope.* This section covers floors, ramps, roofs and similar walking and working surfaces, unless they are specifically covered elsewhere in this subpart.

(2) *Application.* This section does not apply to the following surfaces:

(i) Scaffolds covered in § 1910.30.

(ii) Landings on stairs which are covered in § 1910.25.

(iii) Platforms which are covered in § 1910.31.

(b) *General requirements.* (1) Employees exposed to unprotected sides or edges of surfaces that present a falling hazard of four feet (1.2 m) or more to a lower level or floor holes shall be protected by a fall protection system meeting the requirements of § 1910.28.

(2) Employees on surfaces which are less than four feet (1.2 m) above a lower level, but are above or adjacent to dangerous equipment, materials or operations, shall be protected by a fall protection system meeting the requirements of § 1910.28 to prevent their falling into or onto the hazardous areas.

(3) Employees who are exposed to falling through a covered opening in a surface that presents a fall hazard of four feet (1.2 m) or more to a lower level, and employees who are exposed to falling through skylights, shall be informed of the potential hazard and be protected by one of the following:

(i) The surface shall be designed, covered or reinforced to carry the intended load; or

(ii) Employees shall be protected by a fall protection system in accordance with § 1910.28.

(4) A floor hole less than one foot (30.5 cm) in its least dimension (the shortest distance from the edge of the work surface or toeboard to the object going through the work surface) provided for passage of machinery, piping, or

other equipment that may expand, contract, vibrate and/or move in a similar manner, need only be guarded by a toeboard or equivalent means to prevent the feet of employees from entering the hole or tools from falling through the opening and onto employees below.

**Note:** See § 1910.28(e) for all other floor holes.

(5) Floor hole guards shall be kept in place at all times, except when the nature of work operations require their removal, and where alternative means of protection have been provided.

(6) Employers shall install an appropriate guard, such as a toeboard which complies with § 1910.28, on the perimeter of a walking or working surface, when employees below that surface might be exposed to falling material.

### § 1910.28 Fall protection systems.

(a) *General Requirement.* (1) *Guardrail use.* Employers shall provide a guardrail system as the primary fall protection system for all walking and working surfaces regulated under this subpart unless the use of a guardrail is infeasible. When the use of a guardrail system is infeasible, the employer shall provide an appropriate alternative fall protection such as personal fall protection systems, hole covers, safety nets, etc. which complies with the requirements of this section.

(2) *Exceptions:* Employers that comply with paragraph (d) of this section need not use guardrail systems.

(b) *Guardrail systems and toeboards.* Requirements for suspension scaffold fall protection systems are contained in § 1910.30. All other guardrail systems and their components shall meet the following criteria:

(1) *Top rails.* The top rail or member of a guardrail system shall be capable of withstanding, without failure, a force of at least 200 pounds (890 N) applied within two inches (5 cm) of the top edge of the rail in any downward or outward direction at any point along the top edge. For guardrail systems installed before (*insert date 60 days after the effective date of the final rule in the Federal Register*) when the 200 pound (890 N) test load is applied in a downward direction, the top edge of the guardrail shall not be less than 36 inches (91 cm) above the guarded surface level. For guardrail systems, other than those which comply with paragraph (b)(3)(iii) of this section installed on or after (*insert date 60 days after the effective date of the final rule in the Federal Register*) when the 200 pound (890 N) test load is applied in a downward direction, the top edge of the guardrail shall not be less than 39 inches (1 m) above the guarded surface level. No permanent deformation is permitted in the system when the force is removed.

(2) *Midrails.* (i) Midrails, screens, mesh, intermediate vertical members, solid panels, or equivalent structural members shall be provided between the top rail of the guardrail system and the work surface.

(ii) Midrails and equivalent structural members shall be capable of withstanding, without failure, a force of at least 150 pounds

(667 N) applied in any downward or outward direction at any point along the midrail. No permanent deformation is permitted in the system when the force is removed.

(iii) Midrails and other intermediate members shall be positioned so that the openings in the guardrail system are a maximum of 19 inches (48 cm) in their least dimension.

(3) *Height criteria.* (i) The top member of guardrail systems installed before (*insert date 60 days after the effective date of publication of the final rule in the Federal Register*) shall be at least 36 inches (91 cm) above the work surface under all conditions.

(ii) The height of the top rail or equivalent component of guardrail systems installed on or after (*insert date 60 days after the effective date of the final rule in the Federal Register*) shall be at least 42 inches (1.1 m) above the walking or working surface. Employers may build up the walking and working surface provided the requirements of paragraph (b)(1) of this section are met.

(iii) As an alternative to complying with paragraphs (b)(3)(i) and (b)(3)(ii) of this section, employers may reduce the height of the top surface of a guardrail system to no less than 30 inches (76 cm) at any point, provided the sum of the depth (horizontal distance) of the top edge, and the height of the top edge (vertical distance from the work surface to the top edge of the top member), is at least 48 inches (1.2 m).

(4) *Surfaces of guardrails.* Guardrail systems shall be so surfaced as to prevent injury to an employee from punctures or lacerations, and to prevent snagging of clothing which could cause an employee to fall.

(5) *Size criteria.* Top rails and midrails shall be at least one-quarter inch (0.6 cm) in outside diameter or thickness.

(6) *Access openings.* Employers may use movable guardrail sections using such materials as gates, non-rigid members and chains to provide access when opened and guardrail protection when closed, provided the criteria in paragraphs (b)(1) through (b)(5) of this section. Toeboards are not required in access openings.

(7) *Toeboard requirements.* (i) Toeboards shall be capable of withstanding, without failure, an outward force of at least 50 pounds (222 N) applied at any point in the direction of the exposed perimeter.

(ii) Toeboards shall be at least three and one-half inches (8.9 cm) in vertical height from their top edge to the level of the work surface.

(iii) Toeboards shall not be placed more than one-half inch (1.3 cm) above the work surface. They shall be solid or have openings not over one inch (2.5 cm) in their greatest dimension.

(c) *Handrail and stair rail systems.* (1) *Strength criteria.* Handrails and the top rails of stair rail systems shall be capable of withstanding, without permanent deformation or a loss of support, a force in any downward or outward direction at any point along the top edge, of at least 200 pounds (890 N) applied within two inches (5 cm) of the top edge of the rail.

(2) *Height criteria.* (i) The height of handrails installed before (*insert date 60 days*

*after date of the final rule in the Federal Register*) shall not be less than 30 inches (76 cm) nor more than 42 inches (1.1 m) from the top of the handrail to the surface of the tread in line with the face of the riser at the forward edge of the tread.

(ii) The height of handrails installed on or after (*insert date 60 days after the effective date of the final rule in the Federal Register*) shall not be more than 37 inches (94 cm) nor less than 30 inches (76 cm) when measured in a manner consistent with the method described in (c)(2)(i) above.

(iii) The height of stair rail systems installed before (*insert date 60 days after the effective date of the final rule in the Federal Register*) shall not be less than 30 inches (76 cm) from the upper surface of the tread. This distance shall be measured in a vertical direction at the intersection of the riser face and tread surface, or in the case of open risers, at the forward edge of the tread surface.

(iv) The height of stair rail systems installed on or after (*insert date 60 days after the effective date of the final rule in the Federal Register*) shall be not less than 36 inches (91 cm) when measured in a manner consistent with the method described in (c)(2)(iii) of this section.

(v) A stair rail installed before (*insert date 60 days after the effective date of the final rule in the Federal Register*) may also serve as a handrail when the height of the top edge is not more than 42 inches (1.1 m) nor less than 36 inches (91 cm) when measured at the forward edge of the tread surface.

(vi) A stair rail installed on or after (*insert date 60 days after the effective date of the final rule in the Federal Register*) may also serve as a handrail when the height of the top edge is not more than 37 inches (94 cm) nor less than 36 inches (91 cm) when measured at the forward edge of the tread surface.

(3) *Finger clearance.* The minimum clearance between handrails, including the top edge of stair rail systems serving as handrails, and any obstructions shall be one and one-half inches (4 cm).

(4) *Surfaces.* Handrail and stair rail systems shall be surfaced to prevent injury to employees from punctures or lacerations, and to prevent snagging of clothing.

(5) *Openings in stair rails.* Openings in a stair rail system shall be a maximum of 19 inches (48 cm) in their least dimension.

(6) *Handhold.* Handrails shall have the shape and dimension necessary to provide a firm handhold for employees.

(7) *Projection hazards.* Ends of stair rail systems and handrails shall not present a projection hazard.

(d) *Designated areas.* (1) *General requirements for use.* Employers may establish designated areas which comply with the provisions of this paragraph as an alternative to installing guardrails, where employers demonstrate that employees within the designated areas are not exposed to fall hazards. In addition, the following conditions and requirements must be met in order to use designated areas in lieu of other fall protection measures:

(a) The work must be of a temporary nature, such as maintenance on roof top equipment.



(b) Designated areas shall be established only on surfaces that have a slope from horizontal of 10 degrees or less.

(c) The designated area shall consist of an area surrounded by a rope, wire or chain and supporting stanchions erected in accordance with the criteria in paragraphs (d)(2) through (d)(5) of this section.

(2) *Strength criteria.* (i) After being erected with the line (such as rope, wire or chain) attached, stanchions shall be capable of resisting, without tipping over, a force of at least 16 pounds (71 N) applied horizontally against the stanchion. The force shall be applied 30 inches (76 cm) above the work surface and perpendicular to the designated area perimeter, and in the direction of the unprotected side or edge;

(ii) The line shall have a minimum breaking or tensile strength of 500 pounds (2.2 kN), and after being attached to the stanchions, shall be capable of supporting, without breaking, the loads applied to the stanchions as prescribed in paragraph (d)(2)(i) of this section; and

(iii) The line shall be attached at each stanchion in such a way that pulling on one section of the line between stanchions will not result in slack being taken up in adjacent sections before the stanchion tips over.

(3) *Height criteria.* The line shall be installed in such a manner that its lowest point (including sag) is no less than 34 inches (86 cm) nor more than 39 inches (1 m) from the work surface.

(4) *Visibility criteria.* The line forming the designated area shall be clearly visible from any unobstructed location within the designated area up to 25 feet (7.6 m) away, or at the maximum distance a worker may be positioned away from the line, whichever is less.

(5) *Location criteria.* (i) The stanchions shall be erected as close to the work area as is permitted by the task.

(ii) The perimeter of the designated area shall be erected no less than six feet (1.8 m) from the unprotected side or edge.

(iii) When mechanical equipment is being used, the line shall be erected not less than six feet (1.8 m) from the unprotected side or edge which is parallel to the direction of mechanical equipment operation, and not less than 10 feet (3.1 m) from the unprotected side or edge which is perpendicular to the direction of mechanical equipment operation.

(iv) Access to the designated area shall be by a clear path, formed by two lines, attached to stanchions, which meet the strength, height and visibility requirements of this paragraph.

(e) *Holes.* Covers for holes in floors, roofs and other walking and working surfaces shall comply with the following provisions:

**Note:** See § 1910.27(b)(4) for floor holes provided for the passage of machinery, piping or other equipment.

(1) Covers located in roadways and vehicular aisles shall be capable of supporting, without failure, at least twice the maximum axle load of the largest vehicle expected to cross over the cover.

(2) All other covers shall be capable of supporting, without failure, the maximum intended load of employees, equipment and

material to be applied to the cover at any one time, or 250 pounds (114 kg), whichever is greater.

(3) All covers shall be installed so as to prevent accidental displacement.

(f) *Personal fall protection systems.* All body belts and body harnesses and their associated fall protection systems shall meet the applicable requirements of subpart I of this Part.

(g) *Restraint line systems.* Where an employee is tethered, restraint line systems shall meet the applicable requirements of subpart I in order to prevent a fall from an unprotected side or edge or into an opening.

(h) *Safety net systems.* Safety net systems and their use shall comply with the following provisions:

(1) Safety nets shall be installed as close as practicable under the work surface on which employees are working, but in no case more than 30 feet (9.1 m) below such work surfaces.

(2) Safety nets shall be installed with sufficient clearance under them to prevent contact with the surface or structures below if subjected to an impact equal to that imposed under the required drop test.

(3) Safety nets shall extend outward from the outermost projection of the work surface as follows:

Vertical distance— (working level to horizontal plane of net)	Minimum required horizontal—distance (net outer edge to working surface edge)
Up to 5 feet (1.5 m) .....	8 feet (2.4 m).
More than 5 feet (1.5 m) up to 10 feet (3 m).	10 feet (3 m).
More than 10 feet (3 m)	13 feet (4 m).

(4) Safety nets and their installations shall be capable of absorbing the impact force of a drop test, consisting of a 400 pound (180 kg) bag of sand  $30 \pm 2$  inches ( $76 \pm 5$  cm) in diameter dropped into the net from the highest work surface on which employees are to be protected. Each safety net and its installation shall be successfully drop-tested to meet this requirement at the job site before being used as a fall protection system.

*Exception to paragraph (h)(4) of this section:*

When the employer can demonstrate that such a drop test is not practicable, the net installation may be used if a qualified person certifies that the installation meets the strength requirements of this paragraph (h)(4) and all other requirements of this paragraph (h).

(5) Safety nets which are in use shall be inspected weekly for mildew, wear, damage or deterioration, and shall be removed from service if their required strength has been substantially reduced.

(6) Any materials, scrap pieces or tools which may have fallen into the safety net shall be removed as soon as possible, but at least before the next work shift.

(7) The maximum size of each safety net mesh opening shall not exceed 36 square inches (232 cm<sup>2</sup>), nor be longer than six inches (15 cm) on any side measured center-to-center of mesh ropes or webbing. All mesh

crossings shall be secured to prevent enlargement of the mesh opening.

(8) Each safety net, or section of it, shall have a border rope or webbing with a minimum breaking strength of 5,000 pounds (22.2 kN).

(9) Connections between safety net panels shall be as strong as integral net components, and shall be spaced at intervals not more than six inches (15 cm) apart.

#### § 1910.29 Wall openings.

(a) *Existing wall openings.* Existing wall openings shall be guarded by a fall protection system meeting the applicable requirements of § 1910.28 if their lower edge is less than 36 inches (91.4 cm) above a work surface, and if they present a hazard to employees of falling through and down more than four feet (1.2 m).

(b) *New wall openings.* Wall openings constructed on or after (insert date 60 days after the effective date of the final rule in the **Federal Register**) shall be guarded by a fall protection system meeting the applicable requirements of § 1910.28 if their lower edge is less than 39 inches (1 m) above a work surface, and if they present a hazard to an employee of falling through and down more than four feet (1.2 m).

(c) *Grab handles.* Wall openings shall be provided with accessible grab handles on each side of the opening whenever the work activity requires employees to work through an unprotected opening by reaching through or around the opening. Each grab handle shall be capable of withstanding a maximum horizontal pull-out force equal to two times the intended load, or 200 pounds (890 N), whichever is greater. In addition, employees shall be provided with a fall protection system meeting the requirements of § 1910.28.

#### § 1910.30 Scaffolds.

(a) *Scope and application.* This section applies to two-point adjustable scaffolds, single-point adjustable suspension scaffolds, mobile manually propelled scaffolds, and boatswains' chairs and components when used in general industry. Any other type of scaffolds not specifically covered in this section shall meet the applicable requirements of 29 CFR Part 1926, subpart L.

(b) *Restrictions.* The use of "lean-to" or "shore" scaffolds is prohibited.

(c) *General requirements.* (1) *Scaffold installation and use.* Scaffold installation and use shall meet the following conditions:

(i) Ladders or makeshift devices shall not be used on top of scaffold platforms to increase the height at which employees work.

(ii) Scaffold suspension ropes or devices shall hang vertically without being pulled laterally unless specifically designed and intended for such use.

(iii) When employees on scaffolds are exposed to falling objects, overhead protection shall be provided in such a manner as to deflect or resist penetration of objects that are likely to fall onto the employees.

(iv) Scaffolds shall not be moved horizontally nor altered while they are in use or occupied by employees, except when a scaffold has been specifically designed for such use.

(v) Tools, materials and debris shall not be allowed to accumulate in quantities to cause a hazard.

(vi) Work is prohibited on scaffolds covered with snow, ice or other slippery material except as necessary for removal of such material.

(vii) Work on or from scaffolds is prohibited when winds are above 40 miles per hour (64.4 km/hr) unless the employer can establish that employees are protected from the effects of the wind's force and that the scaffold is properly secured against the wind loads imposed on it. Wind screens shall not be used unless the scaffold is designed for them and the scaffold is secured against wind loads imposed on it.

(viii) Scaffolds shall not be erected, used, or moved closer to exposed and energized power lines than as follows:

(a) For all lines of more than 50 kv, minimum clearance between the lines and all parts of the scaffold shall be 10 feet (3.1 m) plus 0.4 inch (1 cm) for each 1 kv over 50 kv, or twice the length of the line insulator, but never less than 10 feet (3.1 m);

(b) For all insulated lines between 300 volts and 50 kv, the minimum clearance between the lines and all parts of the scaffold shall be 10 feet (3.1 m);

(c) For all insulated lines of less than 300 volts, the minimum clearance between the lines and all parts of the scaffold shall be two feet (0.6 m);

(d) For all lines of any voltage which are uninsulated, the minimum clearance between the lines and all parts of the scaffold shall be 10 feet (3.1 m) for lines of 50 kv and less; and for lines more than 50 kv, 10 feet (3.1 m) plus 0.4 inch (1 cm) for each 1 kv over 50 kv, or twice the length of the line insulator, but never less than 10 feet (3.1 m).

(ix) Where material is being hoisted onto or near a scaffold, tag lines or other equivalent measures to control the hoisted load shall be utilized.

(2) *Suspension ropes.* (i) Suspension ropes shall be capable of supporting, without failure, at least six times the intended load applied or transmitted to that rope.

(ii) Suspension ropes supporting manually-powered suspended scaffolds shall be no less than one-fourth of an inch (.63 cm) diameter steel wire rope or equivalent. The minimum grade of wire rope shall be improved plow steel.

(iii) Suspension ropes supporting suspended powered scaffolds shall be no less than five-sixteenths of an inch (.79 cm) diameter wire rope or equivalent. The minimum grade of wire rope shall be improved plow steel.

(iv) Winding rope hoists shall contain at least four wraps of the suspension rope when the scaffold is at the lowest point of travel. In all other situations, the suspension ropes shall either be of such length that the scaffold can be lowered to the level below without the rope end passing through the hoist, or the rope end shall be configured or provided with a means to prevent its end from passing through the hoist.

(v) Ropes terminating at drums shall be attached to the drum by a positive mechanical means.

(vi) Wire suspension ropes shall not be joined together except by eye splicing with shackles, or by coverplates and bolts.

(vii) Swaged attachments or spliced eyes on wire suspension ropes shall be made only by the wire rope manufacturer or by a qualified person. The swaged attachments or spliced eyes made by a qualified person shall be at least equivalent to devices made by the rope manufacturer.

(viii) Wire rope clips shall be installed by a qualified person, retightened after initial loading, and be inspected and kept tight thereafter.

(ix) Suspension ropes shall be protected from exposure to open flames, hot work, corrosive chemicals or other destructive conditions.

(x) Ropes shall be regularly inspected and serviced. The use of repaired wire rope as suspension rope is prohibited, and defective suspension ropes shall not be used.

(3) *Strength.* Each scaffold and scaffold component, except suspension ropes and guardrail systems, shall be capable of supporting, without failure, its own weight and at least four times the maximum intended load applied or transmitted to that component. Scaffold components selected, built and loaded in accordance with Appendix A of this subpart, will be deemed to meet this requirement.

(4) *Loading of scaffolds.* No scaffold shall be loaded in excess of its maximum intended load. The employer shall inform all employees working with scaffolds of the maximum intended load for the scaffold in use.

(5) *Coating of wood platforms.* Wood platform units shall not be covered with opaque coatings. Unit edges may be marked for purposes of identification. Periodic coating with a wood preservative, fire retardant or slip-resistant coating is permitted, so long as the coating does not obscure the top or bottom wood surface.

(6) *Erection and inspection.* Scaffolds shall be erected and used under the supervision of a qualified person in accordance with applicable manufacturers' recommendations. Scaffolds shall be inspected for visible defects prior to each day's use and after any occurrence which could affect a scaffold's structural integrity. Deficiencies shall be corrected before use.

(7) *Platform width.* Scaffold platform units shall be at least 18 inches (46 cm) wide.

(8) *Platforms.* Platforms at all working levels shall be fully planked or decked with platform units between the front uprights and the guardrail supports as follows:

(i) Platform units shall be placed as close as possible to adjacent units. Any space between adjacent units shall be no more than one inch (2.5 cm) except as necessary to fit around uprights when side brackets are used to extend the width of the platform.

(ii) Where full planking or decking cannot be obtained using standard width units, the platform shall be planked or decked as fully as possible; however, the remaining open space between the platform and guardrail supports shall not exceed nine and one half inches (24 cm).

(9) *Positioning the front edge of a scaffold.* The front edge of all scaffold platforms shall

be positioned as close as practical to the structure being worked, but not more than 14 inches (35 cm) from the face of the structure unless a guardrail system meeting the requirements of § 1910.28 is used. When scaffold frames cannot be positioned within this maximum distance, side brackets or other means may be used to extend the platform width to within 14 inches (35 cm) from the face of the structure being worked.

(10) *Protection of employees working below scaffolds.* Toeboards, overhead protection or other equivalent protection shall be provided to prevent tools or material from falling onto employees working below scaffolds.

(11) *Extension of platform units over supports.* Scaffold platform units, unless cleated or otherwise restrained by hooks or equivalent means at both ends, shall extend over their end supports no less than six inches (15 cm) and not more than 18 inches (46 cm). A unit may extend more than 18 inches (46 cm) over the end support when the unit is designed and installed to support employees on the extended area without tipping, or guarded to prevent access to the cantilevered ends.

(12) *Abutment of platforms.* On scaffolds where units are abutted to create a longer platform, each abutted end shall rest on a separate support, butt plate, or equivalent means of support.

(13) *Overlapping of platforms.* On scaffolds where platform units are overlapped to create a longer platform, the overlap shall occur only over supports, and shall not be less than 12 inches (30.5 cm), unless the planks are nailed together or otherwise restrained to prevent movement.

(14) *Intermixing of components.* Scaffold components manufactured by different manufacturers shall not be intermixed unless the component parts fit together without force or modification, and the resulting scaffold meets the requirements of this section.

(15) *Ladders.* All ladders shall be located so as not to adversely affect the stability of the scaffold.

(16) *Access.* An access ladder, or equivalent safe access, shall be provided to scaffold platforms.

(17) *Gasoline-powered hoists.* Gasoline-powered hoists shall not be located on suspension scaffolds.

(18) *Listing of hoists.* Suspension scaffold mechanically-powered hoists and manually-powered hoists shall be of a type tested and listed by a nationally recognized testing laboratory. Refer to § 1910.7 for definition of nationally recognized testing laboratory.

(19) *Power-operated gears and brakes.* All power-operated gears and brakes on suspension scaffold hoists shall be guarded to prevent employee injury.

(20) *Automatic braking devices.* In addition to the normal operating brake, mechanically-powered hoists on suspension scaffolds shall have a braking device which engages automatically when the normal speed of descent of the hoist is exceeded.

(21) *Manually powered hoists.* Manually powered hoists shall require a positive crank force to descend.

(22) *Support surfaces for suspension scaffold support devices.* All suspension

scaffold support devices such as outrigger beams, cornice hooks, parapet clamps, and similar devices, shall rest on surfaces capable of supporting the reaction forces imposed by the scaffold hoist operating at its maximum rated load.

(23) *Evaluating decks to support intended loads.* When an employer chooses to use outrigger beams in conjunction with a suspended scaffold, a qualified person shall evaluate the direct connections to roof and floor decks before suspension scaffold outrigger beams are used, in order to ensure that such decks are capable of supporting the loads to be imposed.

(24) *Inboard ends of outrigger beams.* The inboard ends of suspension scaffold outrigger beams shall be stabilized by bolts or other direct connections to the floor or roof deck, or they shall have their inboard ends stabilized by counterweights.

(i) Direct connections shall be evaluated before use by a qualified person who shall affirm, based on the evaluation, that the supporting surfaces are capable of supporting the loads to be imposed.

(ii) Counterweights shall be made of non-flammable solid material.

(iii) Counterweights shall be secured by mechanical means to the outrigger beams.

(iv) Counterweights shall not be removed from a scaffold until the scaffold is disassembled.

(v) Outrigger beams shall be secured by tiebacks equivalent in strength to the suspension ropes.

(vi) Tiebacks shall be secured to a structurally sound portion of the building or structure.

(vii) Tiebacks shall be installed parallel to the centerline of the beam.

(25) *Outrigger beams.* Scaffold outrigger beams:

(i) Shall be provided with stop bolts or shackles at both ends;

(ii) Shall be securely fastened together, with the flanges turned out when channel iron beams are used in place of I-beams;

(iii) Shall be installed with all bearing supports perpendicular to the beam centerline;

(iv) Shall be set and maintained with the web in a vertical position;

(v) Where a single outrigger beam is used, shall have the steel shackles or clevises with which the wire ropes are attached to the outrigger beam placed directly over the hoisting machine;

(vi) Shall be made of structural metal or equivalent material; and,

(vii) Shall be restrained to prevent movement.

(26) *Suspension scaffold support devices.* Suspension scaffold support devices such as cornice hooks, roof hooks, roof irons, parapet clamps or similar devices shall be:

(i) Made of mild steel, wrought iron, or materials of equivalent strength;

(ii) Supported by bearing blocks; and

(iii) Secured against movement by tiebacks installed at right angles to the face of the structure whenever possible, and secured to a structurally sound portion of the structure. Vents, standpipes, other piping systems, and electrical conduit shall not be used as points of tie-off for tiebacks. Tiebacks shall be equivalent in strength to the hoisting rope.

(27) *Fall protection for suspension scaffolds.* Employees working on single-point suspension scaffolds and two-point suspension scaffolds shall be protected from falls in the following manner:

(i) All open sides and ends of the scaffolds shall be protected by barriers that meet the following:

(a) At least 36 inches (91 cm) in height;

(b) The top member of barrier shall withstand at least a 100 pound (444 N) force in any downward or outward direction;

(c) The midrails shall withstand at least a 75 pound (333 N) force in any downward or outward direction; and

(d) A standard toeboard meeting the requirements of § 1910.28 is also required when employees below are exposed to hazards from tools, equipment or other objects falling from the scaffold edges;

(ii) Employees on single level scaffolds (one working level) or the top surface of multilevel scaffolds shall be protected by a personal fall protection system meeting the requirements of subpart I, which is attached to either:

(a) a structure (anchorage point) not to the scaffold or the scaffold suspension means, or:

(b) A supplementary platform support line, or a scaffold member which can withstand an impact force of 5,000 pounds (22.2 kN) if supplementary platform support lines are used in conjunction with automatic safety locking devices capable of stopping the fall of the scaffold in the event any of the main suspension lines fail.

(iii) Multilevel platforms and scaffolds with overhead protection shall be provided with supplementary platform support lines and automatic safety locking devices capable of stopping the fall of the loaded platform in the event any of the main suspension lines fail. Employees shall be provided with a personal fall protection system meeting the requirements of subpart I of this part.

Employees working below an obstruction shall be attached to a scaffold member capable of withstanding an impact force of 5,000 pounds (22.2 kN) or greater.

(d) *Two-point adjustable suspension scaffolds (swing stages).* (1) *Platform unit width.* Platform units shall be no more than 36 inches (91 cm) wide, unless designed by a qualified person to be stable under the conditions of use.

(2) *Platform units.* Platform units shall be securely fastened to hangers (stirrups) by U-bolts or by other equivalent means. Light-metal type platforms shall be tested and listed by a nationally recognized testing laboratory.

(3) *Securing scaffolds.* Two-point adjustable suspension scaffolds shall be secured to prevent them from swaying. Window cleaners' anchorages shall not be used for this purpose.

(4) *Bridging scaffolds.* Scaffolds designed for use as two-point suspension scaffolds shall not be bridged or otherwise connected one to another during raising and lowering operations. Two-point suspension scaffolds designed for use in multi-point suspension systems may be bridged one to another if the bridge connections are articulated and the hoists properly sized.

(5) *Passage between scaffolds.* Passage may be made from one platform unit to another

only when the platform units are at the same height, are abutted, and have walk-through stirrups specifically designed for this purpose.

(e) *Single-point adjustable suspension scaffolds.* (1) *Testing and listing.* Single-point adjustable suspension scaffolds including hoists, shall be of a type that is tested and listed by a nationally recognized testing laboratory.

(2) *Combining single-point adjustable suspension scaffolds.* When two single-point adjustable suspension scaffolds are combined to form a two-point suspension scaffolds, the resulting scaffold shall meet the requirements for two-point adjustable suspension scaffolds.

(f) *Mobile manually propelled scaffolds.* (1) *Guarding against falls.* Employees on mobile scaffolds more than 10 feet (3 m) above lower levels shall be protected from falling to lower levels along all open sides and ends of the platform unit by a fall protection system meeting the requirements of § 1910.28.

(2) *Casters and wheels.* Caster stems and wheel stems shall be secured to prevent them from accidentally falling out of their mountings.

(3) *Supporting surfaces.* Mobile scaffolds shall only be used on surfaces that are rigid and capable of supporting the scaffold in a loaded condition. Unstable objects, such as barrels, boxes, loose bricks, or concrete blocks shall not be used to support the scaffolds.

(4) *Leveling.* Screw jacks or equivalent means shall be used when leveling of the scaffold is necessary.

(5) *Securing mobile scaffolds.* Mobile scaffolds being used in a stationary manner shall be secured against unintentional movement.

(6) *Moving mobile scaffolds.* The force used to move a mobile scaffold shall be applied as close to the base as practicable, but no more than five feet (1.5 m) above the supporting surface, and provisions shall be made to stabilize the scaffold to prevent tipping during movement. Surfaces over which the scaffold is to pass shall be free of obstructions and openings that may cause the scaffold to tip.

(7) *Riding mobile scaffolds.* Employees shall not be allowed to ride on scaffolds unless the following conditions are met:

(i) The surface over which the scaffold will pass shall be within three degrees of level, and free of pits, holes, and obstructions;

(ii) The maximum height to base width ratio of the scaffold during movement shall be two to one or less. Outrigger frames may be included as part of the base width dimension;

(iii) Outrigger frames, when used, shall be installed on opposite sides of the scaffold;

(iv) Tools and materials shall be secured to prevent movement or removed from the platform unit, or toeboards shall be installed on all sides of the scaffold;

(v) Employees shall not be on any part of the scaffold which extends outward beyond the wheels, casters, or other supports; and

(vi) Employees on the scaffold shall have advance knowledge of the movement.

(8) *Height to base ratios.* Scaffolds with height to base width ratios more than four to

one shall be restrained by guying, tying, bracing, or other equivalent means sufficient to prevent tipping.

(9) *Preventing swaying and displacement.* Scaffold poles, legs, posts, and uprights shall be plumb, secure, and rigidly braced to prevent swaying and displacement.

(10) *Extending platform units beyond base supports.* Platform units shall not extend outward past the base supports of the scaffold unless outrigger supports or equivalent devices are used and will assure stability.

(g) *Boatswains' chairs.* (1) *Chair strength.* The chair shall be of a size suitable for the intended purpose, and shall be of such strength to hold the intended live load, but not less than 250 pounds (1.1 kN) without failure.

(2) *Tie backs.* Tie backs, if used, shall be approximately perpendicular to the structure face.

(3) *Personal fall protection system.* Each employee shall be protected from falling by body belts or harnesses, lanyards and lifelines, separate from the chair support system. The personal fall protection system shall meet the requirements of subpart I of this part.

(4) *Tackle.* Boatswains' chair tackle shall be correctly sized for the rope being used and the rope shall be "eye" spliced. The breaking strength of the suspension rope shall be at least 4,400 pounds (19.5 kN).

(5) *Seat slings for heat producing processes.* The seat sling shall be constructed of at least three-eighths of an inch (9.5 cm) diameter wire rope when the employee using it is conducting a heat-producing process.

### § 1910.31 Mobile elevating work platforms, mobile ladder stands and powered industrial truck platforms.

(a) *Application.* This section applies to the design and installation of platforms used in conjunction with powered industrial trucks, and to mobile elevating work platforms and mobile ladder stands. The three types of equipment covered by this section shall be collectively be referred to as "units".

(b) *General requirements.* (1) All units shall be designed, installed and maintained to support the maximum intended loads in any configuration that may be used.

(2) All units shall be given a visual inspection prior to use for defects that could cause employee injury. The employer shall ensure that the manufacturers' specifications for inspection and maintenance are met where applicable.

(3) Defective units shall be tagged "Do not use" or with a similar legend in accordance with § 1910.145, and removed from service until repaired by a qualified person.

(4) Employees shall be trained in the safe use of units before they are allowed to use them.

(5) Each unit shall be secured to prevent unintended motion while in use.

(6) The use of any device to achieve additional height on a unit is prohibited.

(7) All surfaces shall be free of hazards that can cause puncture or laceration injuries to employees.

(c) *Mobile elevating work platforms.* (1) *Minimum loading.* Units shall be capable of supporting at least 300 pounds (135 kg).

(2) *Structural safety factors.* (i) All load-supporting structural elements of the units shall have a structural safety factor of not less than two, based on the minimum yield strength of the material.

(ii) All load-supporting structural elements of units that are made of nonductile materials (such as cast iron or fiberglass) shall have a structural safety factor of not less than five, based on the allowable unit stress of the material.

(3) *Maximum platform height.* The maximum platform height of units that only elevate in the vertical plane, without any articulation, shall not exceed four times the minimum base dimensions unless the employer demonstrates that equivalent stability is provided. When greater heights are necessary, properly fitted outrigger frames, guying or bracing shall be provided.

(4) *Platforms.* Unit platforms shall meet the following requirements:

(i) The minimum platform width shall be 18 inches (46 cm).

(ii) The platform shall be provided with a fall protection system meeting the requirements of § 1910.28.

(iii) Toeboards meeting the requirements of § 1910.28 shall be provided on all sides of the platform except across access openings.

(5) *Hydraulic or pneumatic systems.* All components of a hydraulic or pneumatic system, whose failure could result in free descent or an uncontrollable fall of the unit, shall have a bursting strength that exceeds the pressure attained when the system is subjected to the equivalent of four times the system's design factor. All other hydraulic components shall have a bursting strength of at least two times the design factor.

(6) *Safety factor for wire ropes and chains.* Where the platform is supporting its maximum intended load by a system of wire ropes, chains, or both, the safety factor of the wire rope or chain shall not be less than eight to one, based on the ultimate strength of the rope or chain in use.

(7) *Elevating assembly.* The elevating assembly shall be equipped and maintained so that it will not allow a free descent or an uncontrollable fall in the event of the assembly's failure. Any unit equipped with a powered elevating assembly shall be supplied with a clearly marked means for emergency lowering that is accessible from the ground level.

(8) *Outriggers and stabilizers.* Outriggers and stabilizers shall be constructed to prevent unintentional retraction.

(9) *Lateral movement.* The employer shall assure before and during lateral movement of units that:

(i) The platform has been lowered to base level;

(ii) Tools and materials on the platform have been secured from falling or have been removed;

(iii) Employees are off the platform; and

(iv) The area the unit is being moved through has a firm footing and is cleared of obstructions.

(10) *Lowering platforms.* The area surrounding the unit shall be cleared of employees and equipment before the platform is lowered.

(d) *Mobile ladder stands.* (1) *Strength.* Mobile ladder stands shall be capable of

supporting at least four times their intended loading. The minimum design working load shall be calculated on the basis of one or more 200 pound (91 kg) persons, together with 50 pounds (23 kg) of equipment each for a combined weight of 250 pounds (114 kg) for each employee.

(2) *Maximum work surface height.* The maximum work surface heights of mobile ladder stands shall not exceed four times the least base dimension without additional support. When greater heights are needed, outrigger frames shall be employed to achieve this minimum base dimension, or the units shall be guyed or braced to prevent tipping.

(3) *Guardrails and railing systems.* (i) Units having more than five steps or 60 inches (1.5 m) in vertical height to the top step, but less than 10 feet (3 m), placed into service on or after (insert date 60 days after the effective date of the final rule in the **Federal Register**) shall have a railing system on all exposed sides and ends at least 29 inches (73.6 cm) high.

(ii) Units with a maximum work surface height of at least four feet (1.2 m), but less than 10 feet (3 m), placed into service on or after (insert date 60 days after the effective date of the final rule in the **Federal Register**) shall have a railing system on all exposed sides and ends at least 30 inches (76 cm) high.

(iii) All units placed into service before (insert date 60 days after the effective date of the final rule in the **Federal Register**) with a maximum work surface height of 10 feet (3 m) or higher, shall be protected on the exposed sides and ends with a guardrail system at least 36 inches (91 cm) high.

(iii) Units placed into service on or after (insert date 60 days after the effective date of the final rule in the **Federal Register**) and with a maximum work surface height of 10 feet (3 m) or greater, shall have a guardrail system and toeboards meeting the requirements of § 1910.28 of this subpart on all exposed sides and ends.

(iv) Removable gates and non-rigid members such as chains or other means to provide access are permitted in guardrail systems and railing systems provided that the access openings are appropriately guarded when not in use. Toeboards are not required in access openings.

(4) *Handrails.*

(i) Units having more than five steps, or units that are 60 inches (1.5 m) or greater in vertical height to the top step, placed into service before (insert 60 days after the effective date of the final rule in the **Federal Register**) shall be equipped with handrails that are at least 29 inches (73.6 cm) high (measured vertically from the center of the step) on both sides of its steps.

(ii) Units with a maximum work surface height of four feet (1.2 m) or more, placed into service on or after (insert 60 days after the effective date of the final rule in the **Federal Register**) shall be equipped with handrails meeting the requirements of § 1910.28 of the subpart on both sides of its steps.

(5) *Steps.* Steps shall be uniformly spaced and create a uniform slope, with a rise of not less than six and one-half inches (16.5 cm)

nor more than 10 inches (25.4 cm); a depth of not less than seven inches (17.7 cm); and a minimum width of 16 inches (40.6 cm). The slope created by the steps shall be a maximum of 60 degrees measured from the horizontal.

(6) *Locking the unit.* Units shall be locked in position using at least two means of locking when units are in use. Swivel casters, if used, shall be provided with a positive lock on the swivel or wheel or both.

(7) *Riding on units.* Employees shall not ride on mobile ladder stands.

(e) *Powered industrial truck platforms.* (1) *Platforms.* Platforms shall be secured to the lifting carriage or forks of the industrial truck.

(2) *Protection from moving parts.* Employees on a platform shall be protected from the moving parts of the truck.

(3) *Overhead protection.* Overhead protection shall be provided when employees are exposed to objects falling from above.

(4) *Minimum width.* The minimum width of the platform shall be 18 inches (46 cm).

(5) *Fall protection system.* Employees on platforms four feet (1.2 m) or more off the ground shall be protected by a fall protection system meeting the requirements of § 1910.28.

### § 1910.32 Special surfaces.

(a) *Scope and application.* This section regulates fall protection for the walking and working surfaces specified herein. The requirements located in other sections of this subpart apply when not in conflict with the requirements in this section.

(b) *Specific requirements.* (1) *Repair pits and assembly pits.* Repair pits and assembly pits over four feet (1.2 m) but less than 10 feet (3 m) deep need not be protected by a fall protection system meeting the requirements of § 1910.28, provided that the following requirements are met:

(i) Access within six feet (1.8 m) of the edge of the pit is limited to authorized employees;

(ii) Authorized employees shall be trained to recognize and avoid the hazards involved with work around the pit area. (iii) Floor marking in colors contrasting to that of the surrounding area shall be applied, or rope, wire or chain with support stanchions meeting the requirements of § 1910.28(d), or a combination of these, shall be placed at a distance of at least six feet (1.8 m) from the edges of the pits;

(iv) Caution signs stating "Restricted area," "Authorized employees only," or a similar legend, and meeting the requirements of § 1910.145 of this part shall be used to limit entry into the area to authorized employees.

(2) *Slaughtering facilities platforms.* Where the placement of guardrails would cause carcasses being processed under Federal meat inspection regulations to contact working surfaces, the perimeter protection requirements in § 1910.27 do not apply, but the following requirements do apply:

(i) Access to the platform is limited to authorized employees only.

(ii) Toeboards meeting the requirements in § 1910.28(b)(7) or equivalent similar means shall be provided at these work locations to prevent employees from sliding off or falling off the exposed perimeter.

(iii) All of the other sides of platforms shall be guarded as required by § 1910.27 by a fall protection system meeting the requirements of § 1910.28.

(iv) Employees working on the unprotected side of a slaughtering platform shall be trained to recognize and avoid hazards, such as slippery surfaces, that are involved with their work and to understand the importance of the toeboard or other available protective devices.

(3) *Loading racks.* (i) The working side of loading rack platforms which are used for access to tank cars, tank trucks, or similar equipment, need not have fall protection meeting the requirements of § 1910.28.

(ii) All of the other sides of the loading rack shall be guarded as required by § 1910.27 by a fall protection system meeting the requirements of § 1910.28.

(iii) All runways shall be at least 18 inches (46 cm) wide.

(iv) Employees who may be exposed to fall hazards shall be trained to recognize and avoid hazards associated with this type of work.

(4) *Loading docks and teeming tables.*

(i) Employers are not required to install guardrail systems on the working side of platforms such as loading docks and teeming tables, where the employer can demonstrate that the presence of guardrails would prevent the performance of work.

(ii) All of the other sides of the loading docks and teeming tables shall be guarded as required by § 1910.27 by a fall protection system meeting the requirements of § 1910.28.

(iii) Employers shall ensure that employees that may be exposed to fall hazards, are trained to recognize and avoid the hazards associated with this type of work such as, but not limited to, hot surfaces and securing trailers.

(5) *Qualified climbers.* As provided in § 1910.23(a)(2), ladders and step bolts on triangulation, telecommunication, electrical power towers and poles and similar structures, including stacks and chimneys, need not have ladder safety devices, cages or wells if only qualified climbers are permitted to use these ladders or step bolts. Such qualified climbers shall meet the following requirements:

(i) Qualified climbers shall be physically capable (demonstrated through observations of actual climbing activities or by a physical examination) of performing the duties which may be assigned to them;

(ii) Qualified climbers shall have successfully completed a training or apprenticeship program that covered hands-on training for the safe climbing of ladders or step bolts and shall be retrained as necessary to ensure the necessary skills are maintained;

(iii) The employer shall ensure through performance observations, and formal classroom or on-the-job training that the qualified climber has the skill to safely perform the climbing;

(iv) Qualified climbers shall have climbing duties as one of their routine work activities;

(v) Qualified climbers, when reaching their work position, shall be protected by a fall protection system meeting the requirements of § 1910.28.

### Appendix A to Subpart D—Compliance Guidelines

**Note:** The following appendices to subpart D serve as nonmandatory guidelines to assist employers and employees in complying with these sections and to provide other helpful information. These appendices neither add to nor detract from the obligations contained in the OSHA standards.

#### Section 1910.22 General Requirements.

1. *Surface conditions.* The purpose of this section is to provide information to assist employers and employees to assure that walking and working surfaces are maintained free of hazards such as physical obstructions, debris, protruding nails or other fasteners or similar conditions, that could cause employees to slip, trip or fall.

Some hazards, such as snow, water, or ice, which by reason of recent weather or work operations may be present on workplace surfaces, present a slippery surface problem to employers. When these conditions cannot be eliminated completely, the employer can use alternatives such as slip-resistant footwear or handrails or stair rails to aid employees in maintaining their balance on the hazardous surfaces. Normally, slippery surfaces would occur only where snowfalls or freezing weather are of such frequency to make continued clearing or shoveling of workplace parking lots and sidewalks impractical, or where continuous use of water for washing down walking and working surfaces results in constantly slippery surfaces.

An effective housekeeping program may be used to minimize fall hazards where slippery surfaces are due to temporary or intermittent conditions. Absorbents can be used to clean up a spill where oily materials or corrosive liquids are accidentally spilled onto the floor.

2. *Slip-resistance.* A reasonable measure of slip-resistance is static coefficient of friction (COF). A COF of 0.5, which is based upon studies by the University of Michigan and reported in "Work Surface Friction: Definitions, Laboratory and Field Measurements, and a Comprehensive Bibliography," is recommended as a guide to achieve proper slip-resistance. A COF of 0.5 is not intended to be an absolute standard value. A higher COF may be necessary for certain work tasks, such as carrying objects, pushing or pulling objects, or walking up or down ramps.

Slip-resistance can vary from surface to surface, or even on the same surface, depending upon surface conditions and employee footwear. Slip-resistant flooring material such as textured, serrated, or punched surfaces and steel grating may offer additional slip-resistance. These types of floor surfaces should be installed in work areas that are generally slippery because of wet, oily, or dirty operations. Slip-resistant type footwear may also be useful in reducing slipping hazards.

3. *Mobile equipment.* Mobile equipment operated in walkways or passageways creates a hazard to employees similar to any vehicular traffic. Appropriate warnings should be utilized to alert employees that mobile equipment is being used. Warning signs or mirrors can be used at intersections

of walkways or passageways. Flashing lights or audible devices can be mounted on vehicles to warn employees of the presence of vehicles.

Adequate clearance must be provided to permit safe use of walkways, passageways, and aisles by employees when mobile equipment is parked in walkways, passageways, or aisles, and left unattended. Attended means that the operator is within 25 feet (7.5 m) of the vehicle and can see it [see § 1910.178(m)(5)(ii)]. Normally, adequate clearance can be considered as a one-way free passage of 18 inches (46 cm) or greater. However, consideration should be given to the number of employees using the passage; whether traffic will be in both directions; and whether the passageway is part of a means of emergency egress. (See subpart E—Means of Egress for specific requirements.)

4. *Application of loads.* Floor loading limitations would be of greatest concern to those employers engaged in the warehousing or storage of goods and materials. Surfaces that should receive special attention so as not to be overloaded include ramps, lifting platforms, dockboards, scaffolds and ladders.

It is important that employees involved in materials handling be made aware of the loading limitations of any surface upon which they may work or walk. Floor loading of a work surface will vary according to the nature of the work performed. For example, a work surface used as an office would not need the continued control of floor loading that would be necessary if the space was used as a warehouse.

5. *Training.* Employees who are expected to inspect, maintain, and/or repair surfaces must be trained in the skills needed to perform their duties. They should also be aware of the strength of the materials with which they are working, and the load bearing capabilities of the equipment or surfaces they are expected to maintain.

#### Section 1910.23 Ladders

1. *Use of ladders.* Employees should be trained and retrained as necessary to use ladders in the manner for which the ladders were designed to be used. The majority of ladder accidents are apparently due to improper use, placement or selection. The reading and understanding of the hazard warnings and safety use instruction markings that are attached to recently manufactured portable ladders that meet the ANSI standards would be helpful in promoting employee safety.

A general guideline for proper ladder placement for non-self-supported portable ladders is to place the ladder so that the climber's hands would just touch the ladder when the arms are fully extended, and horizontal while the climber is standing

straight facing the ladder with the climber's toes touching the side rails at the base of the ladder.

Employers should make sure that extensions placed on ladder siderails for leveling ladders during placement are installed so that the connectors are secured to the siderails and do not affect their strength. If the ladder is to be used for an extended period of time, it should be secured to the building or structure to prevent its accidental displacement. Employees should also be made aware that the use of individual sections of multisectional ladders as single ladders, and the use of self-supporting ladders in the non-self-supporting mode (*e.g.*, a step ladder folded up and leaned against a wall) is not a safe practice since the ladders are not designed for this use and may slip. Extension ladders need to be equipped with positive locking devices to lock the ladder at the desired climbing length before they may be used.

Employees should not climb ladders while carrying objects in their hands. They should maintain a firm hold on the rungs or siderails and have the necessary objects attached to their belt via straps or loops or have the objects hoisted up by the use of a line once they have reached their work position.

#### Section 1910.24 Step Bolts and Manhole Steps

1. *Step bolts.* Step bolts are bolts connected to poles, towers, or similar structures for use in ascending or descending to different levels. They are normally installed in an alternating pattern on opposite sides of the structural member to be climbed. They are seldom installed directly on opposite sides from one another, except to establish a standing or rest position, although this is an acceptable method of installation.

An effective maintenance program is required to assure the adequacy of step bolts. For example, over a period of extended use, bolts may become bent or otherwise damaged and thus be unsafe to use. Bolts should be checked to assure that they remain in proper position. Since step bolts also serve as hand grips during climbing, they should be kept free of puncture or laceration hazards. It is also important to check the point of anchorage to the structure. Often, due to changing climatic conditions, anchorage nuts may loosen, or fatigue cracks may appear. These are early signs of premature failure of a bolt, and they must not be ignored. These unsafe conditions should be corrected quickly by repair or replacement.

2. *Manhole steps.* Because of the varied environmental conditions found below ground in manhole structures, special consideration should be given to the type and strength of the materials used to manufacture the step, in order to ensure good service life.

Employees climbing through conical sections of manholes may have to climb in positions not normally used because of the design of the conical section. For example, the standards for ladders prohibit climbing ladders where the climbing side of the ladder exceeds 90 degrees from the horizontal. However, in conical sections, the design of the section may be such that climbing at angles exceeding 90 degrees may be necessary for a short distance. If ladder or step offsets or extensions cannot be installed to provide a straight climb, employees should be made aware of the hazards of climbing on the conical sections.

Rungs and steps should be corrugated, knurled, dimpled, coated with skid-resistant material, or otherwise treated to minimize the likelihood of slipping.

#### Section 1910.25 Stairs

Numerous hazards can cause an employee to trip, slip, or fall on stairs. Good housekeeping principles should be followed at all times. Unnecessary obstructions, debris, tools or other loose objects should be kept out of the stairway.

Where carpeting is used on stairs, special attention should be given to the pattern or design on the carpet because some carpet/rug patterns make it difficult to detect the leading edges of the stair tread. It may be necessary to highlight the leading edge of the stair with a different textured material.

If any repairs are necessary, and the work requires the use of tools and materials which would create a hazard, the stairs should be closed to employees until the repairs are made.

There should be adequate lighting on stairways when stairs are in use. Lighting should be maintained and a periodic inspection of stairs should be conducted to assure adequate lighting.

Stairs that may become wet or slippery as part of a work operation or as a result of weather conditions should be equipped with slip-resistant surfaces, such as a non-slip finish or an abrasive paint. To prevent shoes from slipping, exterior stairs should have landings and steps with surfaces that limit the collection of water.

The preferred slope for a stairway is between 30 and 35 degrees from the horizontal.

Figure D-1—Recommended Angles for Stairs, Ramps and Ladders

- A—Ramps: 30° or less
- B—Typical Fixed Stair: 50° or less
- C—Ship Stairs: 50° to 70°
- D—Alternating Tread Stairs: 50° to 70°
- E—Ladders: 60° to 90°

BILLING CODE 4519-26-P

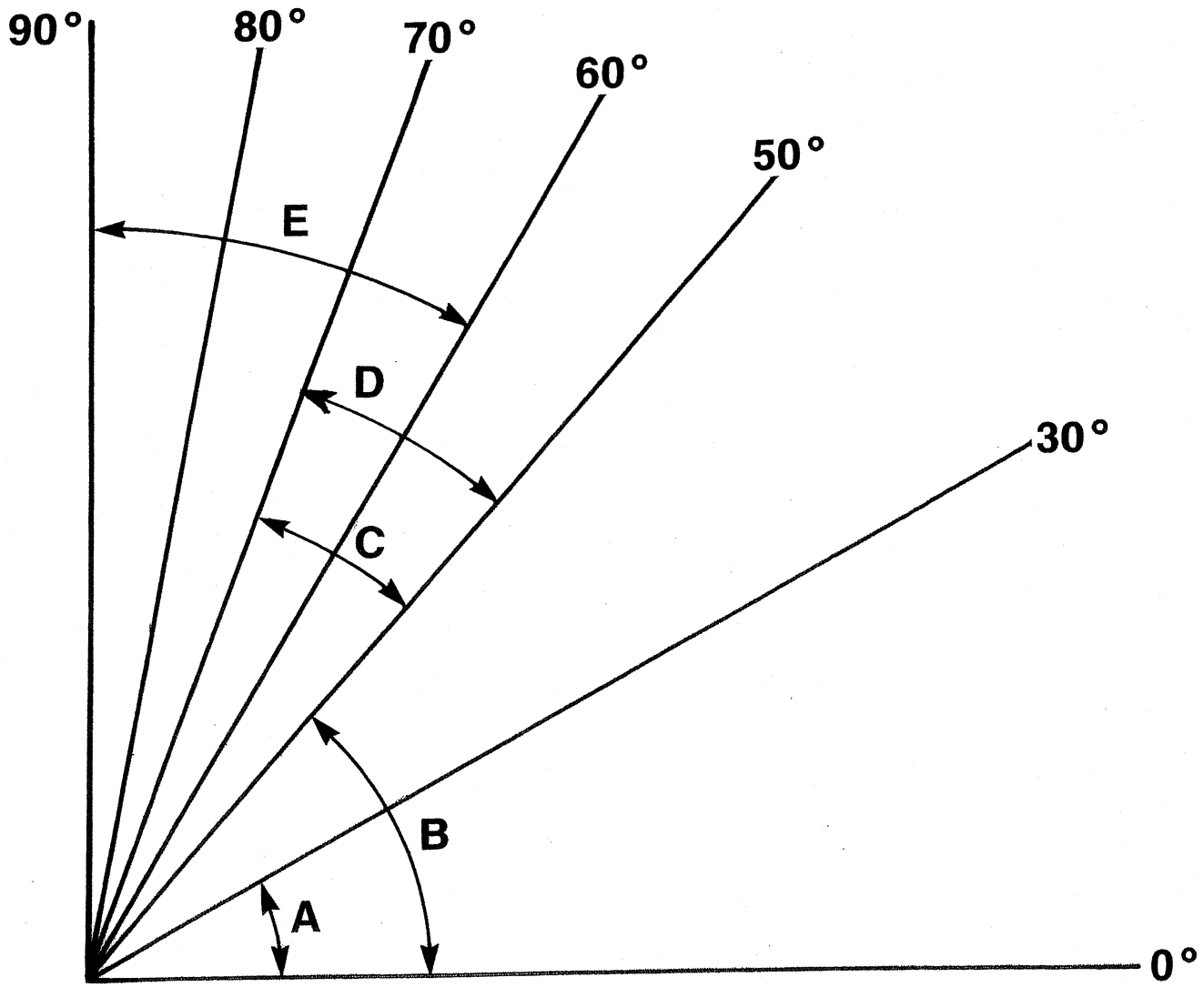

**Figure D—1**

**Figure D—2 Typical Fixed Stair Steps**

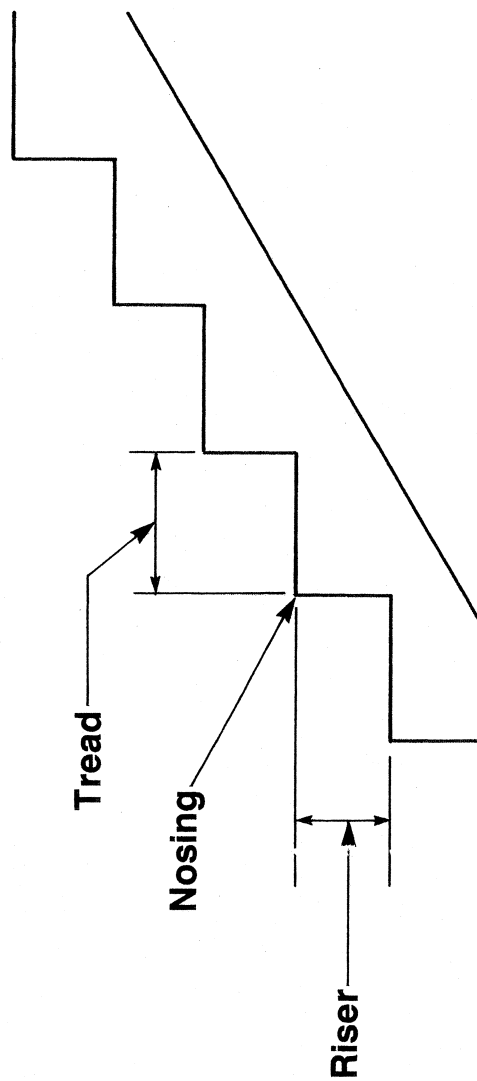

**Dimensions of Typical Fixed Stair Steps:**

**Minimum Tread Width 22 in (55.9 cm)**

**Minimum Tread Depth 8 in (20.3 cm)**

**Riser Height 6½ in to 9½ in (16.5 cm to 24.1 cm)**



**B**

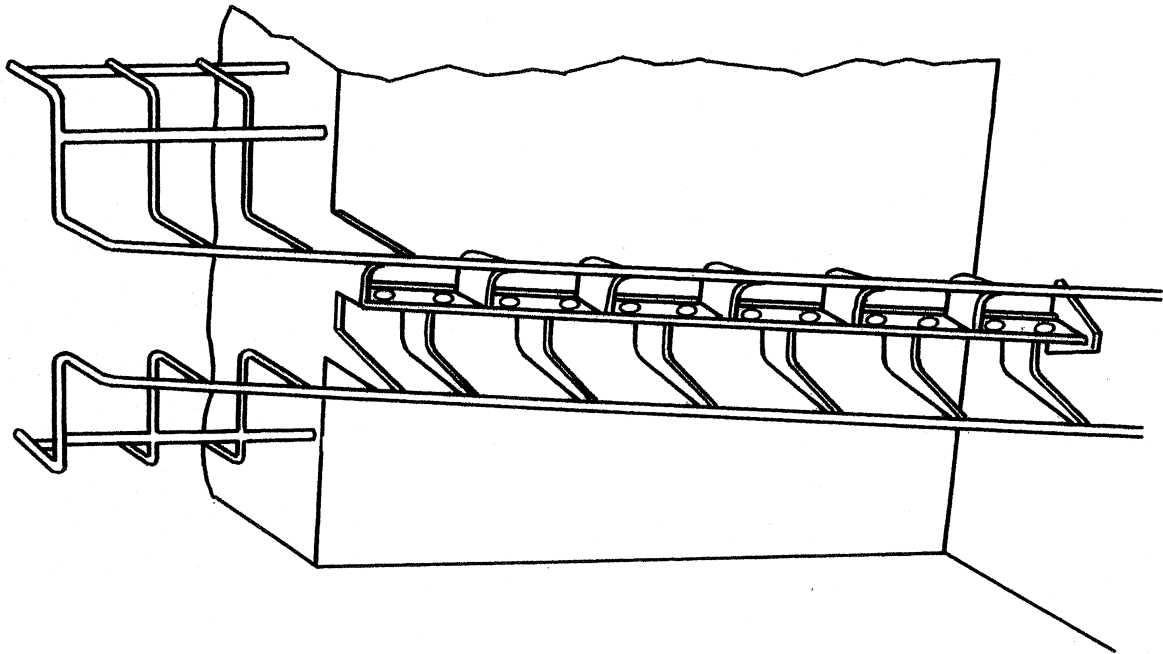

**A**

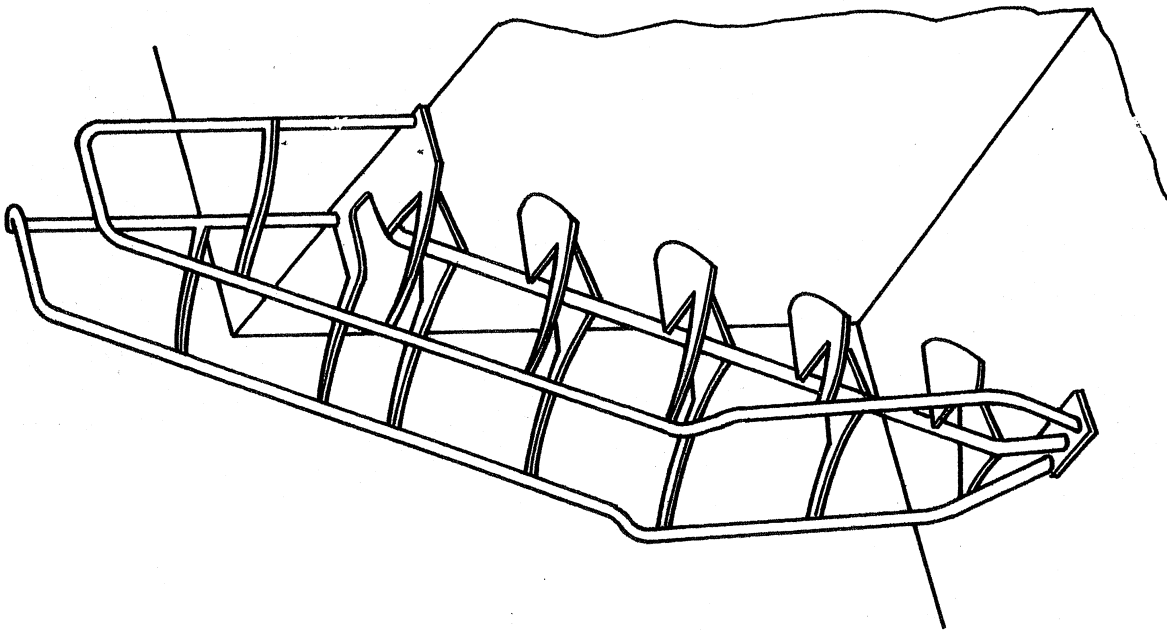

**FIGURE D-3**

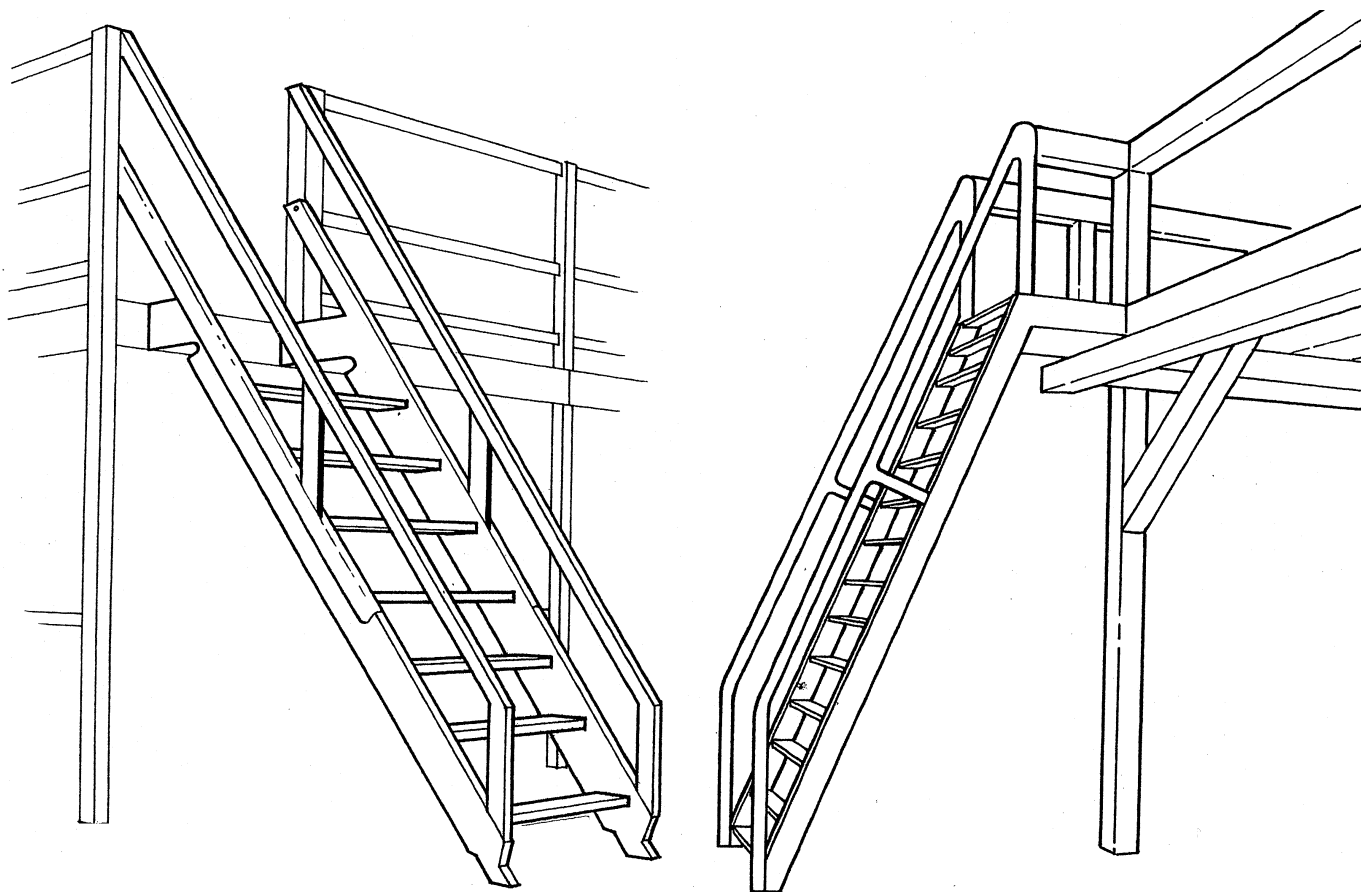

## FIGURE D-4

### BILLING CODE 4510-26-C

#### Section 1910.26 Ramps and Bridging Devices

1. *Preventing vehicles from running off the edge of ramps and bridging devices.* An acceptable method of preventing vehicles from running off the edges of ramps and bridging devices is to attach a curb or a run-off guard to the edge. ASME/ANSI MH14.1, "Loading Dock Levelers and Dockboards," requires a curb or run-off guard to be at least two and three-fourths inches (70 mm) high.

2. *Designated walkway.* An acceptable method of clearly designating and separating walkways on ramps and bridging devices from the portion used for motorized vehicles would be to place curbing or a painted line between the walkway and the vehicle lane. A railing or similar barrier between the two passageway areas would also be acceptable.

3. *Safe means for handling portable ramps and bridging devices.* Using powered industrial trucks or providing handholds for manual movement would be considered safe methods for handling ramps and bridging devices. If the device is to be moved manually, and the weight is such that more than one employee would be required to move it, then a sufficient number of handholds should be provided for the

number of employees required to move it. Rollers may also be used to assist in moving.

4. *Preventing movement of vehicles.* Positive methods of preventing movement of a vehicle are to chock the wheels and use sand shoes on detached trailers.

#### Section 1910.27 Floors and Similar Surfaces

*General requirements.* Areas considered hazardous under § 1910.27 include floor openings, open floor perimeters, sky-lights, platform ledges, and similar structures. Acceptable methods for protecting employees from injury or death due to falling into or off of these exposures include guardrails, floor covers, safety gratings, safety nets, and body belts or harnesses used with lanyards. The employer is encouraged to utilize whatever device suits a specific hazard and which also meets the performance goal of fall prevention. Surfaces with slopes greater than 10 degrees from the horizontal need to be given special consideration when selecting the means of protecting employees from slips, trips, or falls. Factors that should be considered include the increased likelihood of a fall, the added momentum of the fall due to the effect of gravity, and the potential for

an employee to fall or roll through the means of protection.

Acceptable means of protection for steep roofs may include body belts or harnesses and lanyards, safety nets, and catch platforms.

When a floor hole less than two inches (5 cm) in its least dimension constitutes a hazard to employees because of the type of employee footwear being worn, such as spiked heels, precautions such as covers for the hole, or other types of footwear should be used, or foot traffic should be restricted or diverted to another path.

#### Section 1910.28 Fall Protection Systems

1. *Purposes of guardrails, hand-rails, and stair rails.* A guardrail is used to protect employees from falling from the edge of a relatively flat surface. A stair rail is similar in function to a guardrail, its purpose being to protect employees from falling over the edge of an open-sided stairway. A handrail, however, is used to assist employees going up and down stairways, ramps or other walking and working by providing a handhold to grasp to avoid falling. It should be noted that this standard allows the functions of a handrail and stair rail to be combined into one unit, whereby the top rail

of the stair rail also serves as a handrail. The following are examples of the acceptable heights of each component installed on or after (insert date 60 days after the effective date of the final rule in the **Federal Register**):

Guardrail: Minimum 39 inches (1 m). (Optimum height: 42 inches (1.11 m)). Stair rail: Minimum 36 inches (91 cm). (Optimum height: 42 inches (1.1 m)).

Handrail: 30 inches (76 cm) to 37 inches (94 cm) (Optimum height: 33 inches (84 cm)). Combination stair rail/handrail: 36 inches (91 cm) to 37 inches (94 cm).

Ideally (but not required by this standard) an open-sided stairway should have a 42 inch (1.1 m) stair rail, with a 33 inch (84 cm) handrail mounted on it.

2. *Examples of acceptable guardrail components.* The guardrail criteria contained in § 1910.28 is performance-oriented, and provides the employer with many options in materials to use in designing and installing a guardrail system. The following are several examples of guardrail systems considered acceptable by OSHA:

A. *For wood railings:* The posts should be of at least two-inch by four-inch (5.1 cm by 10.2 cm) lumber spaced not to exceed eight feet (2.4 m); the top and intermediate rails should be at least two-inch by four-inch (5.1 cm by 10.2 cm) lumber. If the top rail is made of two one-inch by four-inch (5.1 cm by 10.2 cm) pieces of lumber nailed at right angles to one another, the posts should be spaced on eight-foot (2.4 m) centers, with a two-inch by four-inch (5.1 cm by 10.2 cm) intermediate rail. Selected wood components should be minimum 1500 lb-f/in<sup>2</sup> (1.03 kN/cm<sup>2</sup>) fiber stress construction grade lumber. All dimensions refer to nominal sizes as provided by the American Softwood Lumber Standards.

B. *For pipe railings:* Posts, top rails and intermediate railings should have at least a one and one-half inch (3.8 cm) outside diameter. Posts should be spaced no more than eight feet (2.4 m) on centers.

C. *For structural steel railings:* Posts, top rails and intermediate rails should be of two inch by two inch by three-eighth inch (5.1 cm by 5.1 cm by 0.95 cm) angle iron or of other

metal shapes with equivalent bending strength. Posts should be spaced not more than eight feet (2.4 m) on centers. Structural steel systems may also have posts of two inch by two inch by one-eighth inch (5.1 cm by 5.1 cm by 0.3 cm) angle iron spaced five foot (1.52 m) or less on center with 1-3/4 inch by 1-3/4 inch by 3/16 inch (4.4 cm by 4.4 cm by 0.5 cm) top rail and 1/4 inch by one inch (0.64 cm by 2.54 cm) bar stock midrails.

**Note:** Railings subject to receiving heavy impacts from material-handling equipment or large numbers of employees should be provided with additional strength by using heavier stock, closer spacing of posts, additional bracing or the equivalent.

4. *Guardrails less than 39 inches (1.0 m).* The following are examples of acceptable guardrail systems where the height of the top edge of the guardrail may be reduced to as low as 30 inches (76 cm). Such alternatives could be used in hot-dip galvanizing operations or similar situations where employees need to work with hand tools over the guardrail system.

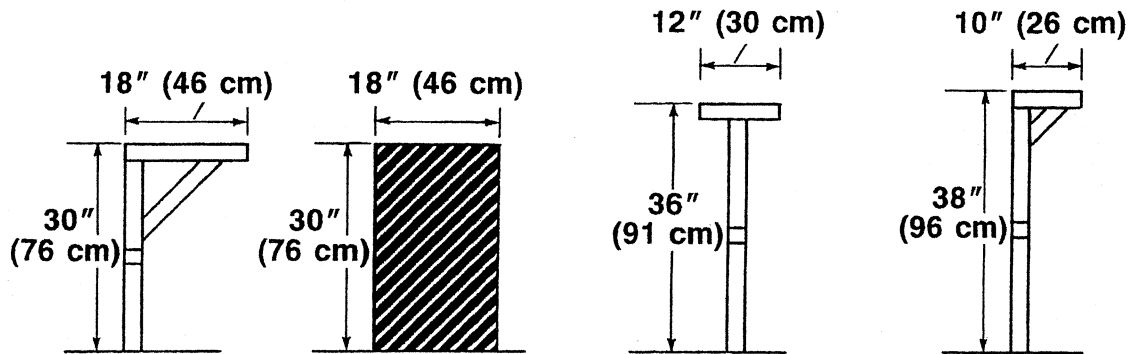

FIGURE D-5

5. *Openings in guardrails.* Openings in guardrails should be small enough to limit the spacing between guardrail members in any one direction to 19 inches (48 cm) or less. A 19 inch (48 cm) diameter ball or sphere can be used to measure spacing of irregularly shaped openings.

In the case of non-rigid guardrail systems, the opening criteria is considered met if the dimensions are proper while the system is not under load. If the size of the openings needs to be reduced, higher toeboards, wider midrails, multiple intermediate rails, perpendicular bars, x-bracing, panels, screen mesh, etc., can be used if they meet the strength, deflection, and permanent deformation requirements. This standard

does not require midrails, provided the 19 inch (48 cm) requirement is met by some other way such as solid barriers, pickets, screening, etc. It should be noted that smaller openings may be required in areas used by the general public, and local building codes may require lesser dimensions.

6. *Surfaces of guardrails.* An acceptable top rail would be a smooth surface such as a pipe, with normal pipe fittings or a smoothly surfaced lumber component. Examples of unacceptable top rails would be rough surfaced lumber, small diameter wire, steel or plastic banding, and guardrails with protruding objects such as splinters, nails, or bolts—all of which could injure an employee's hand.

7. *Testing of guardrail and handrail systems.* In developing and performing tests for guardrail and handrail systems, it is recommended that the test force be applied to the top rail or midrail over an area not to exceed four inches (10.1 cm) by four inches (10.1 cm). In addition, the center of the applied force must be within two inches (5.1 cm) of the top edge of the top rail. The employer should exercise care in determining the most critical locations and directions in which to apply the force (such as a horizontal force at the midpoint of the top rail between supporting posts).

8. *Handrail height requirements.* (a) A diagram of how to measure the height of a handrail is as follows:

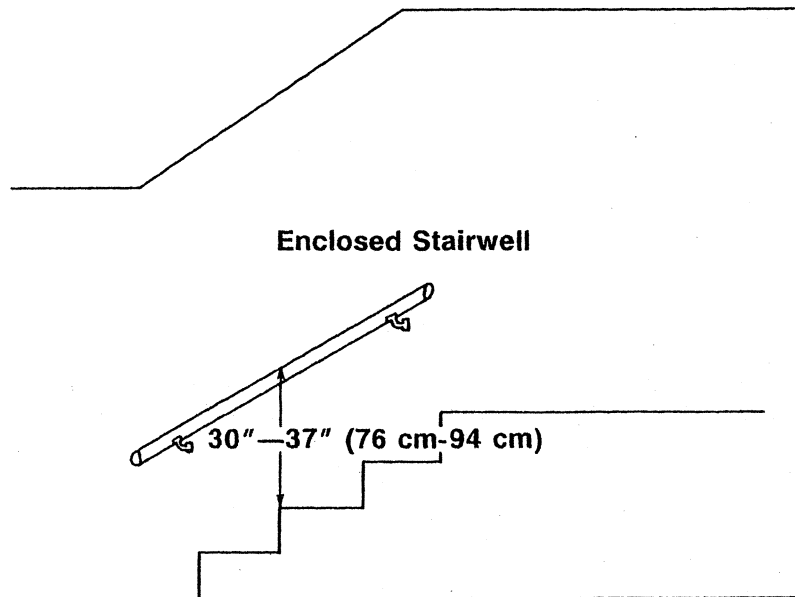

**FIGURE D-6**

(b) An example of the top member of a stair railing which also serves as the handrail is shown below.

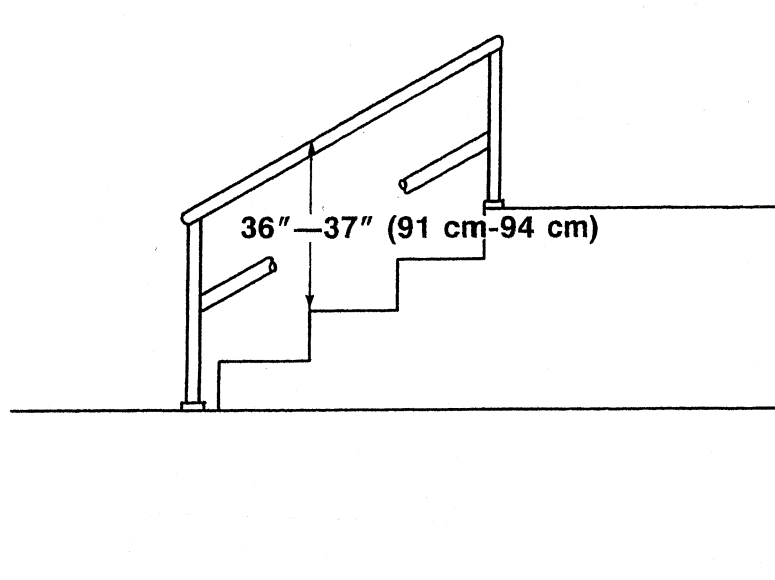
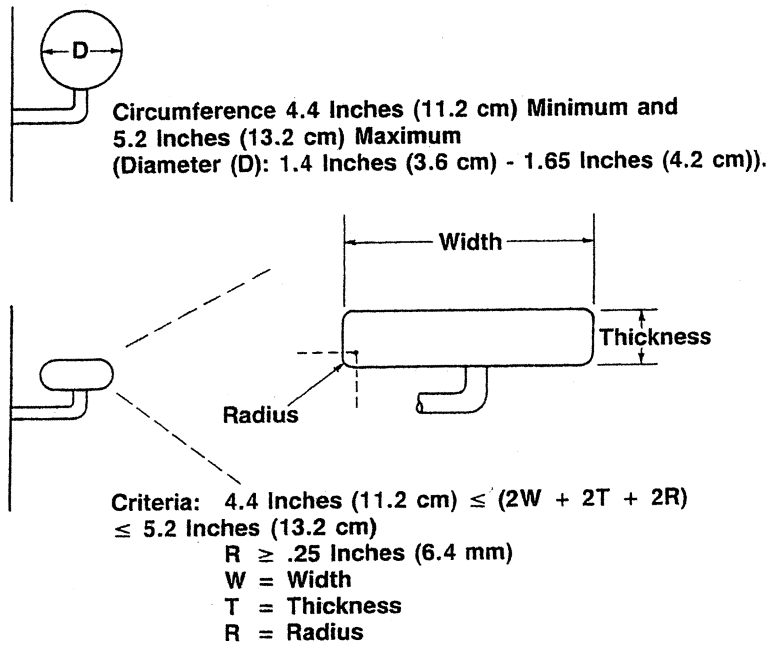

**FIGURE D-7**

9. *Handrail grip dimensions.* It is recommended that newly installed handrails be shaped and designed so that employees

may use their hand grip to their best advantage. These designs permit the fingers to curl around the handrail to provide a

firmer grip. The following are examples of acceptable handrail dimensions used to maximize an employee's grip.

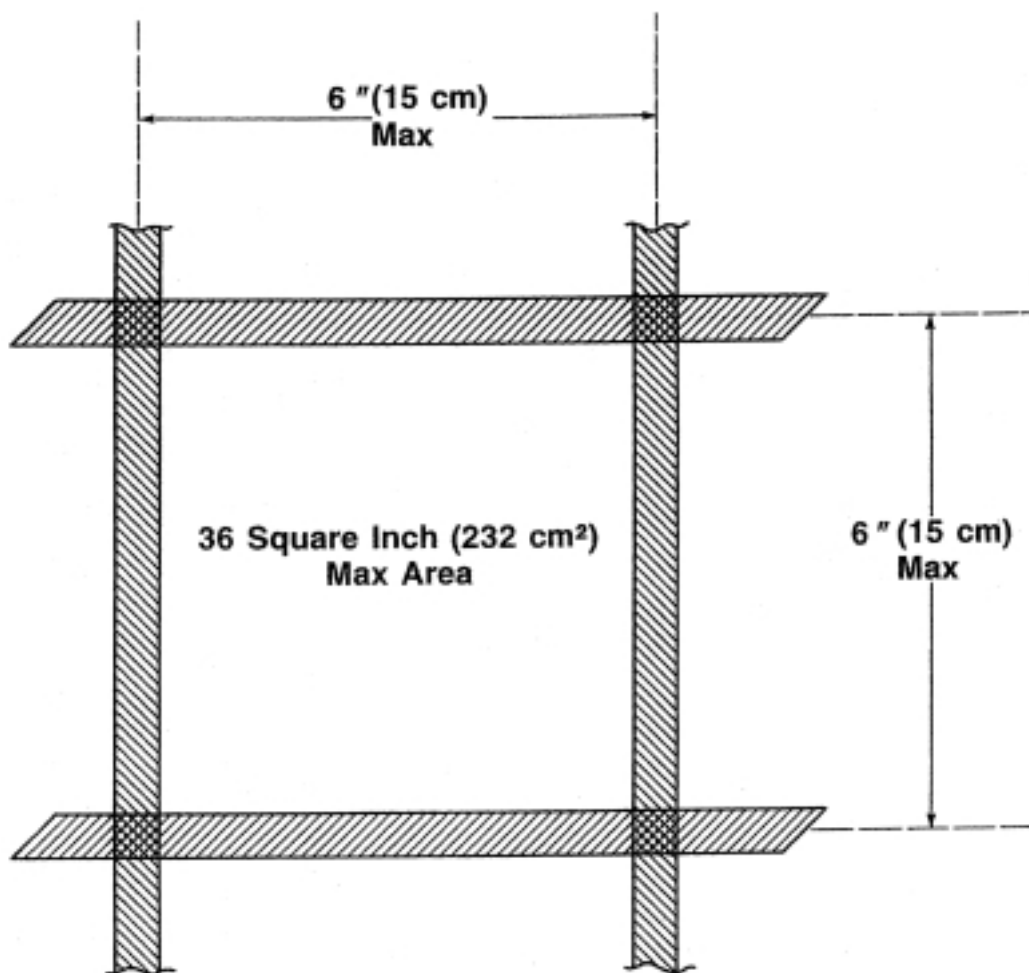

**FIGURE D-8**

10. *Designated area visibility criteria.* One method for meeting the visibility criteria for designated areas is to place a flag made of

high visibility material on the rope, or wire or chain at not more than six foot (1.8 m) intervals.

11. *Openings in safety nets.* The following is a diagram of the maximum opening in a safety net.



**FIGURE D-9**

12. *Safety net construction.* Unduly rigid material should not be used in the construction of safety nets. The use of such material could cause injuries due to the shock of a sudden stop. Elastic type materials such as nylon should be used instead of materials such as manila rope or wire rope.

13. *Safety net testing.* Most safety net designs are tested by the manufacturer. These tests are conducted on sample net panels in accordance with ANSI A10.11, "American National Standard Minimum Requirements for Safety Nets." Such testing assures the user of a suitable product. Since nets are installed in a wide variety of configurations, and provisions for proper attachments to the structure must be decided upon for each job site, each safety net installation should be tested at the work site. Such testing, as provided by the standard, consists of dropping a 400 pound (180 kg) bag of sand,  $30 \pm 2$  inches ( $76 \pm 5$  cm) in diameter into the net from the highest work level to be protected by the net. Consideration should be given to testing the most critical portion of the net installation. In some cases a test at

the job site may not be feasible, or it may expose employees and/or the general public to danger. In these cases the net installation must be certified to be safe by a qualified person.

*Section 1910.29 Wall Openings*

Wall openings are required to be protected to prevent employees from falling into or through the wall openings, and to prevent tools or other materials from falling onto employees below. Examples of acceptable systems for guarding are screens, barriers, rails, guardrail systems, and half doors. These guards may be removable or hinged if access to the wall opening is necessary.

Windows on a stairway, landing, floor, platform, balcony, and other location could also be guarded by slats, grill work or other types of protection. Glass walls are not considered wall openings.

*Section 1910.30 Scaffolds*

1. *General overview.* Section 1910.30 is not intended to require the building of scaffolds either in a specific manner or using a specific

material. Scaffolds used in general industry are also used in the construction industry, and since they are essentially the same scaffolds, the requirements for similar types of scaffolds are essentially the same for the two industries. Therefore, if scaffolds meet the general industry standards they would meet the construction standards, and vice versa. Only the more common types of scaffolds that are used in general industry are specifically regulated by § 1910.30. If a particular type of scaffold is not covered in § 1910.30, the applicable requirements for the scaffold in 29 CFR Part 1926, subpart L, are to be followed.

2. *Overhead protection.* Overhead protection can range from the wearing of hardhats by employees to full overhead planking, depending on the type of objects that can fall onto employees working on scaffolds.

3. *Lumber sizes.* Unless otherwise noted, stated lumber sizes are nominal. Nominal sizes refer to lumber sizes prior to dressing, as well as after dressing, even though the actual size of a piece of dressed lumber is

less than its rough cut size. An example of nominal size would be a 2 x 4 inch (51 x 102 mm) piece of lumber. Traditionally, the lumber would be rough cut to 2 x 4 inches (51 x 102 mm). After dressing, the actual size is appropriately 1½ x 3½ inches (38 x 89 mm). Both the rough 2 x 4 inches (51 x 102 mm) and the dressed 1½ x 3½ inches (38 x 89 mm) lumber would be considered a nominal 2 x 4 inches (51 x 102 mm) size. Lumber References to lumber are not meant to limit the employer to the use of wood. The use of any material of equal or greater strength and durability is acceptable.

4. *Suspension rope.* Suspension ropes need to be visually inspected each day or each shift before use, and also when the rope has not been in use for prolonged periods, or after exposure to detrimental elements such as open flames, hot work, and corrosive chemicals. Proper service such as washing and treating rope after being exposed to adverse conditions, lubricating wire rope, and removing defective sections of rope, may be necessary to keep the rope in safe operating condition. Examples of defective rope include rope where there is severe localized abrasion or scraping; where there is evidence of heat damage; where there is a loss of more than one-third of the original diameter of the outside individual wires; or where there is kinking, crushing, bird caging, or other damage resulting in distortion of the rope structure.

5. *Nails used on scaffolds.* Nails used to construct scaffolds should be driven full length, and should not be subjected to straight pulls.

6. *Snow and ice removal.* OSHA recommends that employees involved in removing snow and ice from scaffolds be protected from falls with body belts or harnesses and lanyards even though guardrails may be provided.

7. *Protecting employees below scaffolds.* Acceptable means of protecting employees below scaffolds from falling objects would include the installation of toeboards or the installation of a screen extending along the entire platform opening between the platform and the guardrail. The screen should consist of No. 19 gauge or heavier U.S. Standard wire, with one-half inch (1.2 cm) or smaller mesh or the equivalent. The use of other types of material such as plywood or expanded metal would also be acceptable.

8. *Tables.* The tables in this appendix relative to scaffolds are based on all load carrying timber members of the scaffold being a minimum of 1,500 lb-f/in<sup>2</sup> (1.03 kN/cm<sup>2</sup>) stress or construction grade lumber. All dimensions are nominal sizes as provided in the American Softwood Lumber Standards, dated January 1970. Except where otherwise noted, only rough or undressed lumber of the size specified will satisfy the minimum requirements of this standard.

9. *Wood planking.* All wood planking selected for scaffold plank use should be graded by rules established by the recognized independent inspection agency for the species of wood used. The maximum permissible spans for 2 x 10 inch (nominal) or 2 x 9 inch (rough) solid sawn wood planks should be as shown in the following table:

Maximum intended load (lb/ft <sup>2</sup> )	Maximum permissible span using full thickness undressed lumber (ft)	Maximum permissible span using nominal thickness lumber (ft)
25 (122 kg/m <sup>2</sup> )	10 (3 m) .....	8 (2.4 m)
50 (244 kg/m <sup>2</sup> )	8 (2.4 m) .....	6 (1.8 m)
75 (366 kg/m <sup>2</sup> )	6 (1.8 m).	

The minimum permissible span for 1¼ x 9 inch (3.2 x 22.9 cm) or wider wood plank of full thickness with a maximum intended load of 50 lb/ft<sup>2</sup> (244 kg/m<sup>2</sup>) should not exceed four feet (1.2 m).

10. *Fabricated planks and platforms.* Fabricated planks and platforms may be used in lieu of solid sawn wood planks. Maximum spans for such units should be as recommended by the manufacturer based on the maximum intended load being calculated as follows:

Rated load capacity	Maximum intended load
Light-duty .....	25 lb/ft <sup>2</sup> (122 kg/m <sup>2</sup> ) applied uniformly over the entire span area.
Medium-duty .....	50 lb/ft <sup>2</sup> (244 kg/m <sup>2</sup> ) applied uniformly over the entire span area.
Heavy-duty .....	75 lb/ft <sup>2</sup> (366 kg/m <sup>2</sup> ) applied uniformly over the entire span area.
One-person .....	250 pounds (113 kg) placed at the center of the span [total 250 pounds (113 kg)].
Two-person .....	250 pounds (113 kg) placed 18 inches (46 cm) to the left and right of the center of the span [total 500 pounds (227 kg)].
Three-person .....	250 pounds (113 kg) placed at the center of the span and 250 pounds (113 kg) placed 18 inches (46 cm) to the left and right of center of the span [total 750 pounds (340 kg)].

**Note:** Platform units used to make scaffold platforms intended for light-duty use should be capable of supporting at least 25 lb/ft<sup>2</sup> (122 kg/m<sup>2</sup>) applied uniformly over the entire unit-span area, or a 250 pound (114 kg) point load placed on the unit at the center of the span, whichever load produces the greater shear force.

11. *Plank-type platform.* An example of an acceptable plank-type scaffold platform would be a platform composed of not less than nominal 2 x 8 inch (7.6 x 20 cm) unspliced planks, properly cleated together on the underside, starting six inches (15.2 cm) from each end. Intervals between each cleat should not exceed 4 feet (1.2 m).

12. *Access.* Acceptable safe access to scaffold platforms could include one or more of the following:

(i) Ladders conforming to the requirements of § 1910.23. The ladders should not be placed in a manner to endanger employees on the scaffold.

(ii) Hook-on or attachable metal ladders specifically designed for use in conjunction with manufactured types of scaffolds.

(iii) Direct access from adjacent scaffolds, structures or personal hoists.

(iv) Ramps or runways and appropriate fall protection systems where applicable.

(v) Internal prefabricated scaffold rungs specifically designed by the manufacturer for use as a ladder.

(vi) Step or stair-type accessories such as ladder stands specifically designed for use with scaffolds.

13. *Counterweights.* The counterweights for suspension scaffolds should be solid, dead weight objects designed so that they will not lose their mass. Examples that may be used are: concrete blocks, steel plates or other non-flowable material.

14. *Body harnesses.* OSHA recommends that full body harnesses be used by employees instead of body belts. When subjected to an actual drop, the body harness distributes the shock more evenly over the body than does the body belt.

15. *Supplementary platform support lines.* Supplementary platform support lines may be used as points of attachments for personal fall protection systems on suspension scaffolds since they act as backups for the primary support lines. In effect, the supplementary platform support lines serve as lifelines for the employees and do not make it necessary to require additional lifelines.

16. *Securing two-point suspension scaffolds.* In addition to direct connection to structures or buildings (except window cleaners' anchors) acceptable ways to prevent scaffold sway would include the use of angulated roping or static lines. Angulated roping is a system of platform suspension in which the upper wire rope sheaves or suspension points are closer to the plane of the structure or building face than the corresponding attachment points on the platform, thus causing the platform to press against the face of the structure or building. Static lines are independent lines secured at their top and bottom ends which are closer to the plane of the structure or building face than the outermost edge of the platform. By drawing the static lines taut, the platform is pushed against the face of the structure or building.

17. *Boatswains' chairs.* An acceptable size and strength for a boatswains' chair would be one made out of one inch (2.5 cm) or thicker wood with a 9 by 17 inch (22.9 by 43.2 cm) seat reinforced by cleats, and with bridle ropes passing through the seat and cleats and crossing diagonally beneath the seat. Seats smaller than 9 by 17 inches (22.9 by 43.2 cm) may be used when access to the work area or the work area itself necessitates a smaller boatswains' chair. Chairs may be made of materials other than wood provided they provide at least the same amount of safety as the wood chairs.

18. *Boatswains' chair rope.* An acceptable rope to be used with a boatswains' chair would be one-half inch (1.2 cm) nylon or

polyester rope. Manila rope is not recommended because of its low strength, and susceptibility to deterioration that is difficult to detect by inspection.

**Section 1910.31 Mobile work platforms, ladder stands, and powered industrial truck platforms.**

1. *Mobile work platforms and ladder stands.* Although not required by this standard, it is recommended that the employer insist on test data or a certification from manufacturers to assure that the mobile work platforms and ladder stands which the employer purchases meet the requirements of this standard.

2. *Safe operating instructions.* It is recommended that mobile elevating work platforms have instructions for safe operation displayed in a permanent and visible location, with at least the following information:

- (i) Warnings, cautions, or restrictions for safe operation.
- (ii) Make, model, serial number, and manufacturer's name and address.
- (iii) Rated work load.
- (iv) Maximum platform height.
- (v) Normal voltage rating of the batteries if battery powered, or line voltage if A.C. powered.
- (vi) Alternate statement of configurations and rated capacities, if applicable.
- (vii) The level of electrical insulation of the work platform, if any.

3. *Standing and climbing on mobile work platforms.* Only systems that are specifically designed by a qualified person to be used with devices to increase working heights should be used when additional height is necessary. It is also recommended that when employees are climbing or descending work platforms, both hands be free to aid in climbing. Tools should be worn on a work belt or hoisted up and down by a line after the worker reaches the work position.

4. *Increasing platform heights.* Acceptable means, other than outriggers, that allow increasing the platform height of mobile ladder stands and platforms could include securing the units with chains or ropes to stabilize the units from tipping. The chains or ropes would have to have sufficient strength to hold the unit and the weight of

the employee(s) as well as any other object that may be placed on it.

**Section 1910.32 Special Surfaces**

1. *Training.* Training is an important factor for employee safety on all special work surfaces. As a minimum, the employer should institute a training program for employees to recognize and avoid the special hazards involved with the particular surface. Training should be conducted to give the employee a better understanding of the actual working conditions and hazards related to the specific hazard. Retraining may be necessary if an employee has been away from one of these activities for a prolonged period of time.

2. *Repair pits and assembly pits.* Repair pits and assembly pits are not only applicable to cars, trucks, and buses, but are also applicable to locomotives, subway and railroad cars and other operations where employees enter a pit and work on overhead objects. The use of a combination of floor markings and stanchions may be used around the exposed edges of the pits provided the overall system is continuous. Warning signs, if used to restrict entry to the pit area, do not necessarily need to be posted at the pit but may be posted in conspicuous locations around the pit area.

3. *Slaughtering facilities.* Acceptable alternative fall protection systems that can be used in slaughtering facilities instead of toeboards to prevent employee's from falling off the open side of the work platform would include the use of safety belts or harnesses and lanyards meeting the requirements of subpart I.

4. *Working sides of loading racks, loading docks, teeming tables, and similar locations.* Even though the working sides of loading racks, loading docks, teeming tables, and similar locations are exempt from the requirements of § 1910.27, it is recommended that safety belts or harnesses, or other fall protection be used whenever possible.

5. *Qualified climbers.* The qualified climber's physical condition should be such that climbing exercise will not impair health and safety. This ability can be determined by physical performance tests. A physical examination by a physician who is aware of the duties that the employee is expected to

perform is acceptable. Successful completion of a training program for the type of structures that are to be climbed will also be considered as proof of the climber's physical capabilities.

It is recommended as a minimum that the training program for qualified climbers consist of classroom training and climbing training. The classroom training should consist of information on the structural characteristics, the types and significance of using safety equipment and the procedures for safe climbing. It should also include discussions of the risks involved with climbing structures and the activities to be performed on the structure, as well as discussions of emergency procedures, accident causes, and factors such as bad weather that tend to increase the risks involved in climbing.

Climbing training should consist of classroom type instruction followed by the individual observing an experienced climber performing one or more climbs on the type of structure for which the individual is being trained to climb. Actual climbing during training should be initiated under close supervision and with the use of redundant safety equipment. The rate of reduction in supervision and the use of safety equipment will be a matter of subjective judgment by the trainer. Climbers should only be permitted to work without fall protection once the employee has demonstrated the necessary ability and skill in climbing structures without fall protection.

**Appendix B to Subpart D—National Consensus Standards**

**Note:** The following appendix to subpart D serves as a nonmandatory guideline to assist employers and employees in complying with these sections and to provide other helpful information. This appendix neither adds to nor detracts from the obligations contained in the OSHA standard.

The following table lists the current national consensus standards which contain information and guidelines that would be considered acceptable in complying with the requirements in the specific sections of subpart D, to the extent that they do not conflict with the standard.

Subpart D	National consensus standard
§ 1910.23 .....	ANSI A14.1, American National Standard for Safety Requirements for Portable Wood Ladders. ANSI A14.2, American National Standard for Safety Requirements for Portable Metal Ladders. ANSI A14.3, American National Standard for Safety Requirements for Fixed Ladders. ANSI A14.4, American National Standard for Safety Requirements for Job-Made Ladders. ANSI A14.5, American National Standard for Safety Requirements for Portable Reinforced Plastic Ladders.
§ 1910.24 .....	ASTM C478, American Society for Testing and Materials Specifications for Precast Reinforced Concrete Manhole Sections. ASTM A394, American Society for Testing and Materials Specifications for Quenched and Tempered Alloy Steel Bolts, Studs, and Other Externally Threaded Fasteners.
§ 1910.25 .....	ANSI A64.1, American National Standard for Requirements for Fixed Industrial Stairs. ANSI/IES RP7, American National Standard Practice for Industrial Lighting.
§ 1910.26 .....	ANSI MH14.1, American National Standard for Industrial Loading Dock Levelers and Dockboards.
§ 1910.27 .....	ANSI A58.1, American National Standard for Minimum Design Loads for Buildings and Other Structure. ANSI A12.1, American National Standard for Safety Requirements for Floor and Wall Openings, Railings, and Toeboards.



Subpart D	National consensus standard
§ 1910.28 .....	ANSI A10.11, American National Standard for Safety Nets Used During Construction, Repair, and Demolition Operations. ANSI A10.14, American National Standard for Requirements for Safety Belts, Harnesses, Lanyards, Lifelines, and Drop Lines for Construction and Industrial Use. ANSI A12.1, American National Standard for Safety Requirements for Floor and Wall Openings, Railings, and Toeboards.
§ 1910.29 .....	ANSI A39.1, American National Standard for Safety Requirements for Window Cleaning. ANSI A12.1, American National Standard for Safety Requirements for Floor and Wall Openings, Railings, and Toeboards.
§ 1910.30 .....	ANSI A92.1, American National Standard for Manually Propelled Mobile Ladder Stands and Scaffolds (Towers).
§ 1910.31 .....	ANSI A10.8, American National Standard for Safety Requirements for Scaffolds. ANSI A92.3, American National Standard for Manually Propelled Elevating Work Platforms. ANSI A92.1, American National Standard for Manually Propelled Mobile Ladder Stands.
§ 1910.32 .....	None.

**Appendix C to Subpart D—References for Further Information**

**Note:** The following appendix to subpart D serves as a nonmandatory guideline to assist employers and employees in complying with these sections and to provide other helpful information. This appendix neither adds to nor detracts from the obligations contained in the OSHA standards.

The following references provide information which may be helpful in understanding and implementing these standards.

**I. General References**

- A. "Accident Prevention Manual for Industrial Operations"; National Safety Council, 444 North Michigan Avenue, Chicago, Illinois 60611.
- B. "The BOCA Basic Building Code"; Building Officials and Code Administrators; Inc., 1313 East 60th Street, Chicago, Illinois 60637.
- C. "Southern Standard Building Code"; Southern Building Code Congress, 1116 Brown-Marx Building, Birmingham, Alabama 35203.
- D. "Uniform Building Code Standards, Volume 1"; International Conference of Building Officials, 50 South Los Robles, Pasadena, California 91101.
- E. "A History of Walkway Slip-Resistance Research at the National Bureau of Standards", Special Publication 565; National Bureau of Standards, National Technical Information Service, Springfield, Virginia 22151.
- F. "A New Portable Tester for the Evaluation of the Slip-Resistance of Walkway Surfaces", Technical Note 953; National Bureau of Standards, National Technical Information Service, Springfield, Virginia 22151.
- G. Miller, James *et al.* "Work Surface Friction: Definitions, Laboratory and Field Measurements, and a Comprehensive Bibliography"; The University of Michigan, Ann Arbor, Michigan 48109. NTIS \*PB 83-243634, PE 83-243626, PB 84-175926).
- H. Chaffin, Don B. *et al.* "An Ergonomic Basis for Recommendations Pertaining to Specific Sections of OSHA Standard, 29 CFR Part 1910, subpart D—Walking and Working Surfaces"; The University of Michigan, Ann Arbor, Michigan 48109.

- I. "Accident Facts-1987 Edition"; National Safety Council, 444 North Michigan Avenue, Chicago, Illinois 60611.
- J. Snyder, Richard G. "Occupational Falls"; The University of Michigan, Ann Arbor, Michigan 48109.
- K. "Occupational Fatalities Related to Roofs, Ceilings and Floors as Found in Reports of OSHA Fatality/Catastrophe Investigations"; U.S. Department of Labor, Office of Statistical Studies and Analysis, 200 Constitution Avenue, N.W., Washington, D.C. 20210.
- L. Ayoub, M. and Gary M. Bakken. "An Ergonomic Analysis of Selected Sections in Subpart D, Walking/Working Surfaces"; Texas University, Lubbock, Texas 79409.
- M. "An Overview of Floor-Slip-Resistance Research with Annotated Bibliography", Technical Note 895; National Bureau of Standards, National Technical Information Service, Springfield, Virginia 22151.
- N. "Occupational Fatalities Related to Miscellaneous Working Surfaces as Found in Reports of OSHA Fatality/Catastrophe Investigations"; U.S. Department of Labor, Office of Statistical Studies and Analysis, 200 Constitution Avenue, NW., Washington, DC 20210.
- O. "A Bibliography of Coefficient of Friction Literature Relating to Slip Type Accidents"; Department of Industrial and Operations Engineering, College of Engineering, University of Michigan, Ann Arbor, Michigan 48104.
- P. "Falls from Elevations Resulting in Injuries"; U.S. Department of Labor, Bureau of Labor Statistics, National Technical Information Service, Springfield, Virginia 22151.

**II. Ladder References**

- A. Chaffin, Don B. and Terrence J. Stobbe. "Ergonomic Considerations Related to Selected Fall Prevention Aspects of Scaffolds and Ladders as Presented in OSHA Standard 29 CFR Part 1910 Subpart D"; The University of Michigan, Ann Arbor, Michigan 48104.
- B. "Occupational Fatalities Related to Ladders as Found in Reports of OSHA Fatality/Catastrophe Investigations"; U.S. Department of Labor, Office of Statistical Studies and Analysis, 200 Constitution Avenue, N.W., Washington, DC 20210.
- C. "Survey of Ladder Accidents Resulting in Injuries"; U.S. Department of Labor, Bureau of Labor Statistics, National

- Technical Information Service, Springfield, Virginia 22151.
- D. "Five Rules for Ladder Safety"; National Safety Council, 444 North Michigan Avenue, Chicago, Illinois 60611.
- E. "A Consumer's Guide to Safe Ladder Selection Care and Use"; U.S. Consumer Product Safety Commission, Washington, DC 20207.
- F. "Portable Ladders"; Data Sheet 1-665-Rev. 82; National Safety Council, 444 North Michigan Avenue, Chicago, Illinois 60611.
- G. "Safety Instructions for the Person Who Climbs to Work, the Care and Use of Fiberglass Ladders"; R. D. Werner Co., Inc., PO Box 580, Greenville, Pennsylvania 16125.

**III. Stair References**

- A. Archa, John *et al.* "Guidelines for Stair Safety"; NBS Building of Science Series 120, National Bureau of Standards, National Technical Information Service, Springfield, Virginia 22151.
- B. Carson, D. H. *et al.* "Safety on Stairs"; National Bureau of Standards, National Technical Information Service, Springfield, Virginia 22151.
- C. Nelson, Gary S. "Engineering-Human Factors Interface in Stairway Treadriser Design"; Texas A & M University of Texas Agricultural Extension Service, College Station, Texas 77843.

**IV. Scaffold References**

- A. "Occupational Fatalities Related to Ladders as Found in Reports of OSHA Fatality/Catastrophe Investigations"; U.S. Department of Labor, Office of Statistical Studies and Analysis, 200 Constitution Avenue, NW., Washington, DC 20210.
- B. "Analysis of Scaffolding Accident Records and Related Employee Casualties", NBSIR 79-1955; National Bureau of Standards, National Technical Information Service, Springfield, Virginia 22151. (NTIS \*PB 80-161466).
- C. "Scaffold Accidents Resulting in Injuries"; U.S. Department of Labor, Bureau of Labor Statistics, Washington, DC 20210.
- D. "Ergonomics Considerations Related to Selected Fall Prevention Aspects of Scaffolds and Ladders as Presented in OSHA Standard 29 CFR Part 1910 Subpart D"; The University of Michigan, Ann Arbor, Michigan 48104.
- E. "Selected Occupational Fatalities Related to Powered, Two-Point Suspension Scaffolds/Powered Platforms as Found in

Reports of OSHA Fatality/Catastrophe Investigations"; U.S. Department of Labor, Office of Statistical Studies and Analysis, 200 Constitution Avenue, NW., Washington, DC 20210.

#### V. Fall Protection References

A. "A Study of Personal Fall-Safety Equipment", NBSIR 76-1146; National Bureau of Standards, National Technical Information Service, Springfield, Virginia 22151.

B. "Guardrails for the Prevention of Occupational Accidents", NBSIR 76-1132; National Bureau of Standards, National Technical Information Service, Springfield, Virginia 22151.

C. Investigation of Guardrails for the Protection of Employees from Occupational Hazards, NBSIR 76-1139; National Bureau of Standards, National Technical Information Service, Springfield, Virginia 22151.

D. A Model Performance Standard for Guardrails, NBSIR 76-1131; National Bureau of Standards, National Technical Information Service, Springfield, Virginia 22151.

\* National Technical Information Services (NTIS), Port Royal Rd., Springfield, Virginia 22151, Phone: (703) 487-4650.

3. The authority citation for subpart F of part 1910 is proposed to be revised as follows:

**Authority:** Secs. 4, 6, 8, Occupational Safety and Health Act of 1970 (29 U.S.C. 653, 655, 657); Secretary of Labor's Order No. 12-71 (36 FR 8754), 8-76 (41 FR 25059) 9-83 (48 FR 35736) or 1-90 (55 FR 9033), as applicable.

Sections 1910.67 and 1910.68 also issued under 29 CFR part 1911.

4. In § 1910.67, paragraph (c)(2)(v) would be revised to read as follows:

#### § 1910.67 Vehicle-mounted elevating and platforms.

\* \* \* \* \*

(c) \* \* \*

(2) \* \* \*

(v) A personal fall protection system which complies with subpart I of this part shall be worn and attached to the boom or basket when working from an aerial lift.

\* \* \* \* \*

5. In § 1910.68, paragraph (b)(4),(b)(8)(ii) and (b)(12) would be revised to read as follows:

#### § 1910.68 Manlifts.

\* \* \* \* \*

(b) \* \* \*

(4) References to other codes and subparts. The following codes, and subparts of this part, are applicable to this section. Safety Code for Mechanical Power Transmission Apparatus ANSI B15.1-1953 (R 1958) and subpart O; and subpart D.

\* \* \* \* \*

(8) \* \* \*

(ii) Construction. The rails shall be standard guardrails with toeboards meeting the provisions in subpart D of this part.

\* \* \* \* \*

(12) Emergency exit ladder. A fixed metal ladder accessible from both the "up" and

"down" run of the manlift shall be provided for the entire travel of the manlift. Such escape ladders shall comply with subpart D of this part.

\* \* \* \* \*

6. The authority citation for subpart N of part 1910 is proposed to be revised as follows:

**Authority:** Secs. 4, 6, 8, Occupational Safety and Health Act of 1970 (29 U.S.C. 653, 655, 657); Secretary of Labor's Order No. 12-71 (36 FR 8754), 8-76 (41 FR 25059) 9-83 (48 FR 35736), or 1-90 (55 FR 9033), as applicable.

Sections 1910.179 also issued under 29 CFR part 1911.

7. In § 1910.179, paragraph (c)(2) would be revised to read as follows:

#### § 1910.179 Overhead and gantry cranes.

\* \* \* \* \*

(c) \* \* \*

(2) Access to crane. Access to the car and/or bridge walkway shall be by a conveniently placed fixed ladder, stairs, or platform requiring no step over any gap exceeding 12 inches (30.5 cm). Fixed ladders shall be in conformance with subpart D of this part.

\* \* \* \* \*

8. The authority citation for subpart R of part 1910 is proposed to be revised as follows:

**Authority:** Secs. 4, 6, 8, Occupational Safety and Health Act of 1970 (29 U.S.C. 653, 655, 657); Secretary of Labor's Order No. 12-71 (36 FR 8754), 8-76 (41 FR 25059) 9-83 (48 FR 35736) or 1-90 (55 FR 9033), as applicable.

Sections 1910.261, 1910.265, and 1910.268 also issued under 29 CFR part 1911.

9. In § 1910.261, paragraphs (a)(3)(ii), (a)(3)(iv), (a)(3)(v) and (a)(3)(vi) would be removed.

10. Paragraphs (b)(3), (c)(3)(i), (c)(15)(ii), (e)(4), (g)(2)(iii), (g)(8), (g)(13)(i), (h)(1), (j)(4)(ii), (j)(4)(iv), (j)(5)(i), (k)(6), (k)(13)(i) and (k)(15) of § 1910.261 would be revised to read as follows:

#### § 1910.261 Pulp, paper and paperboard mills.

\* \* \* \* \*

(b) \* \* \*

(3) Floors and platforms. Floors, platforms, and work surfaces shall be maintained in accordance with subpart D of this part.

\* \* \* \* \*

(c) \* \* \*

(3) \* \* \*

(i) Ladders and gangplanks with railings to boat docks shall comply with subpart D of this part, and shall be securely fastened in place.

\* \* \* \* \*

(15) \* \* \*

(ii) Where conveyors cross passageways or roadways, a horizontal platform shall be provided under the conveyor, extended out from the sides of the conveyor a distance equal to one and one-half times the length of the wood handled. The platform shall extend the width of the road plus two feet (.61 m) on each side, and shall be kept free of wood

and rubbish. The edge of the platform shall be provided with toeboards or other protection to prevent wood from falling, in accordance with subpart D of this part.

\* \* \* \* \*

(e) \* \* \*

(4) Runway to the jack ladder. The runway from the pond or unloading dock to the table shall be protected with standard handrails and toeboards. Inclined portions shall have cleats or equivalent nonslip surfacing, and shall be in accordance with subpart D of this part. Protective equipment shall be provided for persons working over water.

\* \* \* \* \*

(g) \* \* \*

(2) \* \* \*

(iii) The worker shall be provided with eye protection, a supplied air respirator and a personal fall protection system meeting the requirements of subpart I of this part during inspection, repairs or maintenance of acid towers. The line shall be extended to an attendant stationed outside the tower opening.

\* \* \* \* \*

(8) Chip and sawdust bins. Steam or compressed-air lances, or other devices, shall be used for breaking down the arches caused by jamming in chip lofts. No workers shall be permitted to enter a bin unless provided with an attached personal fall protection system meeting the requirements of subpart I of this part, and with an attendant stationed at the bin.

\* \* \* \* \*

(13)(i) Blow-pit openings preferably shall be on the side of the pit instead of on the top. Openings shall be as small as possible when located on top, and shall be provided with railings, in accordance with subpart D of this part.

\* \* \* \* \*

(h) \* \* \*

(1) Bleaching engines. Bleaching engines, except the Bellmer type, shall be completely covered on the top, with the exception of one small opening large enough to allow filling, but too small to admit an employee. Platforms leading from one engine to another shall have standard guardrails in accordance with subpart D of this part.

\* \* \* \* \*

(j) \* \* \*

(4) \* \* \*

(ii) Guardrails shall be provided around beaters where tub tops are less than 42 inches (1.06 m) from the floor, in accordance with (b)(3) of this section and subpart D of this part.

\* \* \* \* \*

(iv) When beaters are fed from the floor above, the chute opening, if less than 42 inches (1.06 m) from the floor, shall be provided with a guardrail system meeting the requirements of subpart D of this part or other equivalent enclosures. Openings for manual feeding shall be sufficient only for entry of stock, and shall be provided with at least two permanently secured crossrails or other fall protection systems that meet the requirements of subpart D of this part.

\* \* \* \* \*

(5) \* \* \*

(i) All pulpers having the top or any other opening of a vessel less than 42 inches (1.06 m) from the floor or work platform shall have such openings guarded by guardrail systems meeting the requirements of subpart D of this part or other equivalent enclosures. For manual changing, openings shall be sufficient only to permit the entry of stock, and shall be provided with at least two permanently secured crossrails, or other fall protection systems meeting the requirements of subpart D of this part.

\* \* \* \* \*

(k) \* \* \*

(6) Steps. Steps of uniform rise and tread with nonslip surfaces shall be provided at each press, conforming to subpart D of this part.

\* \* \* \* \*

(13) \* \* \*

(i) A guardrail complying with subpart D of this part shall be provided at broke holes.

\* \* \* \* \*

(15) Steps. Steps or ladders complying with subpart D of this part and tread with nonslip surfaces shall be provided at each calendar stack. Handrails and hand grips complying with subpart D of this part shall be provided at each calendar stack.

\* \* \* \* \*

8. In § 1910.265, paragraphs (c)(3)(i), (c)(4)(v), (c)(5)(i), (c)(10), (d)(2)(ii)(g) and (f)(6) would be revised to read as follows:

§ 1910.265 Sawmills.

\* \* \* \* \*

(c) \* \* \*

(3) \* \* \*

(i) Floor and wall openings. All floor and wall openings shall be protected as prescribed in subpart D of this part.

\* \* \* \* \*

(4) \* \* \*

(v) Elevated platforms. Where elevated platforms are used routinely on a daily basis, they shall be equipped with stairways or fixed ladders, conforming to subpart D of this part.

\* \* \* \* \*

(5) \* \* \*

(i) Construction. Stairways shall be constructed in accordance with subpart D of this part.

\* \* \* \* \*

(10) Ladders. Ladders shall be installed and maintained as specified in subpart D of this part.

\* \* \* \* \*

(d) \* \* \*

(2) \* \* \*

(ii) \* \* \*

(g) Guardrails, walkways, and standard handrails shall be installed in accordance with subpart D of this part.

\* \* \* \* \*

(f) \* \* \*

(6) Ladders. A fixed ladder complying with the requirements of subpart D of this part or other adequate means shall be provided to permit access to the roof. Where controls and machinery are mounted on the roof, a permanent stairway with standard handrail

shall be installed in accordance with the requirements of subpart D of this part.

\* \* \* \* \*

9. In § 1910.268, paragraph (g)(1) would be revised, paragraph (g)(2) would be removed, and paragraph (h) would be revised to read as follows:

§ 1910.268 Telecommunications.

\* \* \* \* \*

(g) Personal climbing equipment. (1) General. Body belts and pole straps shall be provided and the employer shall ensure their use when work is performed at positions more than four feet (1.2 m) above the ground, on poles, and on towers, except as provided in paragraph (n)(7) and (n)(8) of this section. Personal fall protection systems shall meet the applicable requirements set forth in subpart I of this part. The employer shall ensure that all climbing equipment is inspected prior to each day's use to determine that it is in safe working condition. Production samples of personal fall protection systems shall be certified by the manufacturer or a qualified person as having been tested in accordance with and as meeting the requirements of subpart I of this part as applicable.

\* \* \* \* \*

(h) Ladders. Ladders, step bolts, and manhole steps shall meet the applicable requirements of subpart D of this part with the following exceptions:

(1) Portable wood ladders shall not be painted, but may be coated with a translucent non-conductive coating.

(2) Rolling ladders used in telecommunication centers shall have a minimum inside width between siderails of at least eight inches (20.3 cm).

[FR Doc. 90-7800 Filed 4-9-90; 8:45 am]

PART 1910—OCCUPATIONAL SAFETY AND HEALTH STANDARDS

1. The authority citation for subpart I of part 1910 is proposed to be amended as follows:

Authority: Sec. 6 and 8 of the Occupational Safety and Health Act of 1970 (29 U.S.C. 653, 655, 657), Secretary of Labor's Order No. 12-71 (36 FR 8754), 8-76 (41 FR 25059), and 9-83 (48 FR 35736), or 1-90 (55 FR 9033), as applicable. Subpart I is also issued under 29 CFR part 1911.

2. Sections 1910.128, 1910.129, 1910.130 and 1910.131, and Appendices A, B, and C are proposed to be added to subpart I to read as follows:

\* \* \* \* \*

Subpart I—Personal Protective Equipment

Sec.

1910.128 Definitions and general requirements for personal fall protection systems.

1910.129 Personal fall arrest systems.

1910.130 Positioning device systems.

1910.131 Personal fall protection systems for climbing activities.

\* \* \* \* \*

Appendix A to Subpart I—Personal Fall Protection Systems

Appendix B to Subpart I—References for Further Information

Appendix C to Subpart I—Test Methods and Procedures for Personal Protective Systems

§ 1910.128 Definitions and general requirements for personal fall protection systems.

(a) Scope and application. (1) This section establishes definitions and general performance criteria for all personal fall protection systems. Additional requirements for the different types of personal fall protection systems are contained in §§ 1910.129, 1910.130, and 1910.131 of this subpart.

(2) This section applies only where referenced by a specific OSHA standard.

(b) Definitions

Anchorage means a secure point of attachment for lifelines, lanyards, or deceleration devices, and which is independent of the means of supporting or suspending the employee.

Belt terminal means an end attachment of a window cleaner's positioning system used for securing the belt or harness to single or double-headed anchors.

Body belt means a strap with means both for securing about the waist and for attaching to a lanyard, lifeline, or deceleration device.

Body harness means a design of straps which may be secured about the employee in a manner to distribute the fall arrest forces over at least the thighs, pelvis, waist, chest, and shoulders with means for attaching it to other components of a personal fall arrest system.

Buckle means any device for holding the body belt or body harness closed around the employee's body.

Carrier means the track of a ladder safety device consisting of a flexible cable or rigid rail which is secured to the ladder or structure by mountings.

Competent person means a person who is capable of identifying hazardous or dangerous conditions in any personal fall arrest system or any component thereof, as well as in their application and use with related equipment.

Connector means a device which is used to couple (connect) parts of the system together. It may be an independent component of the system, such as a carabiner, or it may be an integral component of part of the system (such as a buckle or dee-ring sewn into a body belt or body harness, or a snaphook spliced or sewn to a lanyard or self retracting lanyard.).

Deceleration device means any mechanism, such as rope grabs, ripstitch lanyards, specially-woven lanyards, tearing or deforming lanyards, automatic self retracting lifelines/lanyards, etc., which serve to dissipate a substantial amount of energy during a fall arrest, or otherwise limit the energy imposed on an employee during fall arrest.

Deceleration distance means the additional vertical distance a falling employee travels, excluding lifeline elongation and free fall distance, before stopping, from the point at

which the deceleration device begins to operate. It is measured as the distance between the location of an employee's body belt or body harness attachment point at the moment of activation (at the onset of fall arrest forces) of the deceleration device during a fall, and the location of that attachment point after the employee comes to a full stop.

Double-head anchor means two anchor heads in the window frame on each side of a window, being used simultaneously and not singly, as part of a window cleaner's positioning system.

Equivalent means alternative designs, materials or methods to protect against a hazard which the employer can demonstrate will provide an equal or greater degree of safety for employees than the methods, materials or designs specified in the standard.

Free fall means the act of falling before the personal fall arrest system begins to apply force to arrest the fall.

Free fall distance means the vertical displacement of the fall arrest attachment point on the employee's body belt or body harness between onset of the fall and just before the system begins to apply force to arrest the fall. This distance excludes deceleration distance, lifeline and lanyard elongation, but includes any deceleration device slide distance or self-retracting lifeline\lanyard extension before they operate and fall arrest forces occur.

Ladder belt means a belt which may be attached to a fixed ladder or a secured portable ladder while the employee is performing work from the ladder.

Ladder safety device means a device other than a cage or well, designed to help prevent accidental falls from ladders, or to limit the length of such falls. A ladder safety device usually consists of a carrier, safety sleeve, and body belt or harness.

Lanyard means a flexible line of rope, wire rope, or strap which generally has a connector at each end for connecting the body belt or body harness to a deceleration device, lifeline, or anchorage.

Lifeline means a component consisting of a flexible line for connection to an anchorage at one end to hang vertically (vertical lifeline), or for connection to anchorages at both ends to stretch horizontally (horizontal lifeline), and which serves as a means for connecting other components of a personal fall arrest system to the anchorage.

Lineman's body belt means a belt which consists of a belt strap and dee-rings, and may include a cushion section or a tool saddle.

Personal fall arrest system means a system used to arrest an employee in a fall from a working level. It consists of an anchorage, connectors, a body belt or body harness and may include a lanyard, deceleration device, lifeline, or suitable combinations of these.

Personal fall protection system means a personal fall arrest system, a positioning device system, or a personal fall protection system for climbing activities which protects a worker from falling, or safely arrests a worker's fall, should a fall occur.

Personal fall protection system for climbing activities means a system worn or

attached to an employee designed to prevent an employee from being injured should the employee fall while ascending or descending.

Pole strap means a strap used for supporting the employee while working on poles, towers, or platforms. Snap-hooks on each end are provided for attachment to dee-rings on the lineman's body belt.

Positioning device system means a system of equipment or hardware which, when used with its body belt or body harness, allows an employee to be supported on an elevated vertical surface, such as a wall or windowsill, and work with both hands free.

Qualified person means one with a recognized degree or professional certificate and extensive knowledge and experience in the subject field who is capable of design, analysis, evaluation and specifications in the subject work, project, or product.

Restraint (tether) line means a line from an anchorage or between anchorages, to which the employee is secured in such a way as to prevent the employee from walking or falling off an elevated work surface.

Rope grab means a deceleration device which travels on a lifeline and automatically frictionally engages the lifeline and locks so as to arrest the fall of an employee. A rope grab usually employs the principle of inertial locking, cam/lever locking, or both.

Saddle belt means a belt which has additional straps for supporting an employee in a sitting position at a work station.

Safety sleeve means the moving component with locking mechanism of a ladder safety device which travels on the carrier and connects the carrier to the body belt or harness.

Self-retracting lifeline/lanyard means a deceleration device which contains a drum-wound line which may be slowly extracted from, or retracted onto, the drum under slight tension during normal employee movement, and which, after onset of a fall, automatically locks the drum and arrests the fall.

Single-head anchor means one anchor head in the window frame on each side of the window used for attaching each end (belt terminal) of a window cleaner's strap.

Snap-hook means a connector comprised of a hook-shaped member with a normally closed keeper, or similar arrangement, which may be opened to permit the hook to receive an object and, when released, automatically closes to retain the object. Snap-hooks may generally be one of two types:

(1) The locking type with a self-closing, self-locking keeper which remains closed and locked until unlocked and pressed open for connection or disconnection, or

(2) The non-locking type with a self closing keeper which remains closed until pressed open for connection or disconnection.

Tie-off means the act of an employee, wearing personal fall protection equipment, to connect directly or indirectly to an anchorage. It also means the condition of an employee being connected to an anchorage.

Window cleaner's belt means a belt which consists of a waist-belt, an integral terminal runner or strap, and belt terminals.

Window cleaner's positioning system means a system which consists of a window cleaner's belt secured to window anchors.

(c) General requirements. (1) Connectors shall be drop forged, pressed or formed steel, or made of equivalent materials.

(2) Connectors shall have a corrosion-resistant finish, and all surfaces and edges shall be smooth to prevent damage to interfacing parts of the system.

(3) Lanyards and vertical lifelines which tie-off one employee shall have a minimum breaking strength of 5,000 pounds (22.2 kN).

(4) Self-retracting lifelines and lanyards which automatically limit free fall distance to two feet (0.61 m) or less shall have components capable of sustaining a minimum static tensile load of 3,000 pounds (13.3 kN) applied to the device with the lifeline or lanyard in the fully extended position.

(5) Self-retracting lifelines and lanyards which do not limit free fall distance to two feet (0.61 m) or less, ripstitch lanyards, and tearing and deforming lanyards shall be capable of sustaining a minimum tensile load of 5,000 pounds (22.2 kN) applied to the device with the lifeline or lanyard in the fully extended position.

(6) Dee-rings and snap-hooks shall be capable of sustaining a minimum tensile load of 5,000 pounds (22.2 kN).

(7) Dee-rings and snap-hooks shall be proof-tested to minimum tensile load of 3,600 pounds (16 kN) without cracking, breaking, or taking permanent deformation.

(8) Snap-hooks shall be dimensionally compatible with the member to which they are connected so as to prevent unintentional disengagement of the snap-hook by depression of the snap-hook keeper by the connected member, or shall be a locking type snap-hook designed to prevent disengagement of the snap-hook by the contact of the snap-hook keeper by the connected member.

(9) Horizontal lifelines shall be designed, installed, and used under the supervision of a qualified person, as part of a complete personal fall arrest system, which maintains a safety factor of at least two.

(10) Anchorages, including single- and double-head anchors, shall be capable of supporting at least 5,000 pounds (22.2 kN) per employee attached, or shall be designed, installed, and used under the supervision of qualified person as part of a complete personal fall protection system which maintains a safety factor of at least two.

(11) Restraint lines shall be capable of sustaining a tensile load of at least 3,000 pounds (13.3 kN).

(12) Lifelines and carriers shall not be made of natural fiber rope.

(13) Snap-hooks shall not be connected to each other.

(14) Personal fall protection systems and their components shall be used only for employee fall protection.

(15) Personal fall protection systems or their components subjected to impact loading shall be immediately removed from service and shall not be used again for employee protection unless inspected and determined by a competent person to be undamaged and suitable for reuse.

(16) Before using personal fall protection systems, and after any component or system is changed, employees shall be trained in the

application limits of the equipment, proper hook-up, anchoring and tie-off techniques, methods of use, and proper methods of equipment inspection and storage.

(17) Personal fall protection systems shall be inspected prior to each use for mildew, wear, damage, and other deterioration. Defective components shall be removed from service if their function or strength has been adversely affected.

#### § 1910.129 Personal Fall Arrest Systems

(a) Scope and application. (1) This section establishes performance criteria and care and use requirements for personal fall arrest systems. It applies only where referenced by a specific OSHA standard.

(b) System performance criteria. (1) Personal fall arrest systems shall, when stopping a fall:

(i) Limit maximum arresting force on an employee to 900 pounds (4 kN) when used with a body belt.

(ii) Limit maximum arresting force on an employee to 1,800 pounds (8 kN) when used with a body harness;

(iii) Bring an employee to a complete stop and limit maximum deceleration distance an employee travels to 3.5 feet (1.07 m); and

(iv) Have sufficient strength to withstand twice the potential impact energy of an employee free falling a distance of six feet (1.8 m), or the free fall distance permitted by the system, whichever is less.

(2)(i) When used by employees having a combined person and tool weight of less than 310 pounds (140 kg), personal fall arrest systems which meet the criteria and protocol contained in 1910.129 of Appendix C shall be considered as complying with the provisions of paragraphs (b)(1)(i) through (b)(1)(iv) of this section.

(ii) When used by employees having a combined tool and body weight of 310 pounds (140 kg) or more, personal fall arrest systems which meet the criteria and protocols contained in 1910.129 of Appendix C may be considered as complying with the provisions paragraphs (b)(1)(i) through (b)(1)(iv) of this section, provided that the criteria and protocols are modified appropriately to provide proper protection for such heavier weights.

(c) Care and use.

(1) Unless the snap-hook is designed for the following connections, snap-hooks shall not be engaged:

(i) Directly to webbing, rope or wire rope;

(ii) To each other;

(iii) To a dee-ring to which another snap-hook or connector is attached;

(iv) To a horizontal lifeline; or

(v) To any object which is incompatibly shaped or dimensioned in relation to the snap-hook such that unintentional disengagement could occur by the connected object being able to depress the snaphook keeper and release itself.

(2) Devices used to connect to a horizontal lifelines which may become a vertical lifeline shall be capable of locking in either direction on the lifeline.

(3) Personal fall arrest systems shall be rigged such that an employee can neither free fall more than six feet (1.8 m), nor contact any lower level.

(3) Personal fall arrest systems shall be worn with the attachment point of the body belt located in the center of the wearer's back, and the attachment point of the body harness located in the center of the wearer's back near shoulder level, or above the wearer's head.

(5) When vertical lifelines are used, each employee shall be provided with a separate lifeline.

(6) The employer shall provide for prompt rescue of employees in the event of a fall or shall assure that employees are able to rescue themselves.

(7) Lifelines shall be protected against being cut or abraded.

#### § 1910.130 Positioning device systems.

(a) Scope and application. This section establishes additional application and performance criteria for positioning device systems. It applies only where referenced by a specific OSHA standard.

(b) System performance criteria. (1) A window cleaner's positioning system shall be capable of withstanding without failure a drop test consisting of a six (1.83 m) drop of a 250 pound (113 kg) weight. The system shall limit the initial arresting force to not more than 2,000 pounds (8.89 kN), with a duration not to exceed two milliseconds, and shall limit any subsequent arresting forces imposed on the falling employee to not more than 1,000 pounds (4.45 kN).

(2) All other positioning device systems shall be capable of withstanding without failure a drop test consisting of four foot (1.2 m) drop of a 250 pound (113 kg) weight.

(3) Positioning device systems which meet the tests contained in 1910.130 of Appendix C, shall be deemed in compliance with the provisions of paragraphs (b)(1) and (2) of this section.

(c) Lineman's body belt and pole strap systems. The following additional provisions shall apply to lineman's body belt and pole strap systems:

(1) All materials used for pole straps shall be capable of withstanding an alternating current (A.C.) dielectric test of not less 25,000 volts per foot (82,020 volts per meter) "dry" for three minutes, without visible deterioration.

(2) Materials shall not be used if leakage current exceeds one milliamperere when a potential of 3,000 volts is applied to electrodes positioned 12 inches (30.5 cm) apart.

(3) In lieu of alternating current (A.C.), direct current (D.C.) may be used to evaluate the requirements 1910.130(c)(1) and (2). The D.C. voltage used shall be two times the A.C. voltage used for these tests.

(4) The cushion part of the lineman's body belt shall be at least three inches (7.6 cm) in width.

(5) Suitable copper, steel, or other liners shall be used around the bars of dee-rings where they are attached to body belts to prevent weakening of the body belt due to wear and tear.

(d) Window cleaner's belts, anchorages and systems. The following additional provisions shall apply to window cleaner's belts, anchorages and systems.

(1) The belt shall be designed and constructed so that belt terminals will not

pass through their fastenings on the belt or harness should one terminal become loosened from its window anchor. The length of the runner from terminal tip to terminal tip shall be eight feet (2.44 m) or less.

(2) The anchors on a building to which the belt is to be fastened shall be installed in the side frames of the window or in the mullions at a point not less than 42 inches (106.7 cm) nor more than 51 inches (129.5 cm) above the window sill. Each anchor, and the structure to which it is attached, shall be capable of supporting a minimum load of 6,000 pounds (26.5 kN).

(3) Rope which has sustained wear or deterioration materially affecting its strength may not be used.

(4) Anchors whose fastenings or supports are damaged or deteriorated shall be removed or rendered unusable by detachment of the anchor head(s).

(5) An installed single or double-head anchor may not be used for any purpose other than attachment of a window cleaner's belt.

(6) Both belt terminals shall be attached to separate single or double-head anchors during the cleaning operation.

(7) Cleaning work is not permitted on a sill or ledge on which there is snow, ice, or any other slippery condition, nor on a weakened or rotted sill or ledge.

(8) A window cleaner may work from a windowsill only if a minimum standing room in relation to slope is provided as follows:

(i) When the sill width is at least four inches (10.1 cm), work is permitted with a slope of the sill from horizontal up to 15 degrees;

(ii) For slopes between 15 and 30 degrees from horizontal, but in no case greater than 30, the minimum acceptable sill width is four inches (10.1 cm), plus 0.4 inches (1.0 cm) for every degree of slope greater than 15 degrees.

(9) The window cleaner shall attach at least one belt terminal to a window anchor before climbing through the window opening. The belt shall not be completely disconnected from both anchors until the employee is back inside the window opening.

(10) The window cleaner shall not pass from one window to another while outside the building, but shall return inside and repeat the belt terminal attachment procedure for each window as described in paragraph (d)(9) of this section.

#### § 1910.131 Personal fall protection systems for climbing activities.

(a) Scope and application. This section establishes additional application and performance criteria for personal fall protection systems for climbing activities. It applies only where referenced by a specific OSHA standard.

(b) Design criteria for systems components.

(1) Personal fall protection systems for climbing activities shall permit the employee using the system to ascend or descend without continually having to hold, push or pull any part of the system, leaving both hands free for climbing.

(2) The connection between the carrier or lifeline and the point of attachment to the body belt or harness shall not exceed nine inches (23 cm) in length.

(3) Personal fall protection systems for climbing activities shall be activated within two feet (.61 m) after a fall occurs, in order to limit the descending velocity of an employee to seven feet/sec (2.1 m/sec) or less.

(4) Mountings for rigid carriers shall be attached at each end of the carrier, with intermediate mountings, as necessary, spaced along the entire length of the carrier, to provide strength necessary to stop employee falls.

(6) Mountings for flexible carriers shall be attached at each end of the carrier. When the system is exposed to wind, cable guides utilized with a flexible carrier shall be installed at a minimum spacing of 25 feet (7.6 m) and a maximum spacing of 40 feet (12.2 m) along the entire length of the carrier, to prevent wind damage to the system.

(7) The design and installation of mountings and cable guides shall not reduce the design strength of the ladder.

(c) System performance criteria. (1) Ladder safety devices and their support systems shall be capable of withstanding without failure a drop test consisting of an 18 inch (.41 m) drop of a 500 pound (226 kg) weight.

(2) All other personal fall protection systems for climbing activities shall be capable of withstanding without failure a drop test consisting of a four foot (1.2 m) drop of a 250 pound (113 kg) weight.

#### Appendix A to Subpart I—Personal Fall Protection Systems

##### § 1910.128 Personal fall protection systems.

The following information generally applies to all personal fall protection systems.

1. *Selection and use considerations.* The kind of personal fall protection system selected should match the particular work situation, and any possible free fall distance should be kept to a minimum. Many systems are generally designed for a particular work application, such as a lineman's body belt and pole strap, a rebar belt and chain assembly, or a window cleaner's belt. Consideration should be given to the particular work environment. For example, the presence of acids, dirt, moisture, oil, grease, etc., and their effect on the system, should be evaluated. Hot or cold environments may also have an adverse affect on the system. Wire rope should not be used where an electrical hazard is anticipated. As required by the standard, consideration must also be given to having means available to rescue an employee should a fall occur, since the suspended employee may not be able to reach a work level independently.

Where lanyards, connectors, and lifelines are subject to damage by work operations, such as welding, chemical cleaning, and sandblasting, protection of the component, or other securing systems should be used. Unless designed for use in a personal fall arrest system, linemen's pole straps should not be used as lanyards. Chest harnesses should not be used where there is a possibility of any free fall. The employer should fully evaluate the work conditions and environment (including seasonal

weather changes) before selecting the appropriate personal fall protection system. Once in use, the system's effectiveness should be monitored. In some cases, a program for cleaning and maintenance of the system may be necessary.

2. *Testing Considerations.* Before purchasing a personal fall protection system, an employer should insist that the supplier provide information about the system based on its performance during testing of the system using recognized test methods so that the employer will know that the system meets the criteria in this standard. Otherwise, the employer will not know if the equipment is in compliance unless samples he has purchased are tested. Appendix C contains test methods which are recommended for evaluating the performance of any system. Not all systems need to be tested; the performance of a system can often be based on data and calculations derived from testing of similar systems, provided that enough information is available to demonstrate similarity of function and design.

3. *Component compatibility considerations.* Ideally, a personal fall protection system is designed, tested, and supplied as a complete system. However, it is common practice for lanyards, connectors, lifelines, deceleration devices, body belts and body harnesses to be interchanged since some components wear out before others. The employer and employee should realize that not all components are interchangeable. For instance, a lanyard should not be connected between a body belt (or harness) and a deceleration device of the self-retracting type since this can result in additional free fall for which the system was not designed. In addition, positioning device components, such as pole straps, ladder hooks and rebar hooks, should not be used in a fall arrest system unless they meet the requirements of § 1910.129. Also, a ladder hook may not be used with a dee-ring, nor in a system which would permit any significant free fall distance (more than two feet (0.61 m)). Rebar hooks should be sized and used to be compatible with the size of rebar to which they will be attached. Any substitution or change to a personal fall protection system should be fully evaluated or tested by a competent person to determine that it meets the standard, before the modified system is put in use.

4. *Employee training considerations.* OSHA recommends that before the equipment is used, employees should be trained in the application limits; proper anchoring and tie-off techniques, including determination of elongation and deceleration distance; methods of use; and inspection and storage of the system. Careless or improper use of the equipment can result in serious injury or death. Employers and employees should become familiar with the material in this standard and appendix, as well as manufacturers' recommendations, before a system is used. Of uppermost importance is the reduction in strength caused by certain tie-offs (such as using knots, tying around sharp edges, etc.) and maximum permitted free fall distance. Also to be stressed are the importance of inspections prior to use, the limitations of the equipment, and unique

conditions at the worksite which may be important in determining the type of system to use.

5. *Instruction considerations.* Employers should obtain comprehensive instructions from the supplier as to the system's proper use and application, including, where applicable:

- a. The force measured during the sample force test;
- b. The maximum elongation measured for lanyards during the strength test;
- c. The deceleration distance measured for deceleration devices during the force test;
- d. Caution statements on critical use limitations;
- e. Application limits;
- f. Proper hook-up, anchoring and tie-off techniques, including the proper dee-ring or other attachment point to use on the body belt and harness for fall arrest;
- g. Proper climbing techniques;
- h. Methods of inspection, use, cleaning, and storage; and
- i. Specific lifelines which may be used. This information should be provided to employees during training.

6. *Inspection considerations.* OSHA recommends that personal fall protection systems must be regularly inspected. Any component with any significant defect, such as cuts, tears, abrasions, mold, or undue stretching; alterations or additions which might affect its efficiency; damage due to deterioration; contact with fire, acids, or other corrosives; distorted hooks or faulty hook springs; tongues unfitted to the shoulder of buckles; loose or damaged mountings; non-functioning parts; or wearing or internal deterioration in the ropes must be withdrawn from service immediately, and should be tagged or marked as unusable, or destroyed.

##### § 1910.129 Personal fall arrest systems.

1. *Special considerations.* As required by the standard, when personal fall arrest systems are used, special consideration must be given to rescuing an employee should a fall occur. The availability of rescue personnel, ladders or other rescue equipment should be evaluated. In some situations, equipment which allows employees to rescue themselves after the fall has been arrested may be desirable.

2. *Tie-off considerations.* Employers and employees should at all times be aware that the strength of a personal fall arrest system is based on its being attached to an anchoring system which does not significantly reduce the strength of the system (such as an eye-bolt/snap-hook anchorage). Therefore, if a means of attachment is used that will reduce the strength of the system, that component should be replaced by a stronger one, but one that will also maintain the appropriate maximum deceleration characteristics. The following is a listing of some known strength reduction situations.

- a. *Tie-off using a knot in the lanyard or lifeline (at any location).* The strength of the line can be reduced by 50 percent, or more, if a knot is used. Therefore, a stronger lanyard or lifeline should be used to compensate for the knot, or the lanyard length should be reduced (or the tie-off

location raised) to minimize free fall distance, or the lanyard or lifeline should be replaced by one which has an appropriately incorporated connector to eliminate the need for a knot.

b. *Tie-off around a "H" or "I" beam or similar support.* Strength can be reduced as much as 70 percent by the cutting action of the beam edges. Therefore, the employer should either provide a webbing lanyard or a wire core lifeline around the beam to protect the lanyard or lifeline from the beam edges, or greatly minimize the potential free fall distance.

c. *Tie-off around rough or sharp surfaces.* This practice reduces strength drastically. Such a tie-off is to be avoided; an alternate means should be used such as a snap-hook/dee-ring connection, a tie-off apparatus (steel cable tie-off), an effective padding of the surfaces, or an abrasion-resistant strap around the supporting member.

d. *Horizontal lifelines.* Horizontal lifelines, depending on their geometry and angle of sag, may be subjected to greater loads than the impact load imposed by an attached component. When the angle of horizontal lifeline sag is less than 30 degrees, the impact force imparted to the lifeline by an attached lanyard is greatly amplified. For example, with a sag angle of 15 degrees the force amplification is about 2:1, and at five degrees sag it is about 6:1. Depending on the angle of sag, and the line's elasticity, the strength of the horizontal lifeline and the anchorages to which it is attached should be increased a number of times over that of the lanyard. Extreme care should be taken in considering a horizontal lifeline for multiple tie-offs. The reason for this is that in multiple tie-offs to a horizontal lifeline, if one employee falls, the movement of the falling employee and the horizontal lifeline during arrest of the fall may cause other employees to also fall. Horizontal lifeline and anchorage strength should be increased for each additional employee to be tied-off. For these and other reasons, the design of systems using horizontal lifelines must only be done by qualified persons. Testing of installed lifelines and anchors prior to use is recommended.

e. *Eye-bolts.* It must be recognized that the strength of an eye-bolt is rated along the axis of the bolt, and that its strength is greatly reduced if the force is applied at right angles to this axis (in the direction of its shear strength). Care must also be exercised in selecting the proper diameter of the eye to avoid creating a roll-out hazard (accidental disengagement of the snap-hook from the eye-bolt).

f. *Knots.* Due to the significant reduction in the strength of the lifeline (in some cases, as much as a 70 percent reduction), the sliding hitch knot should not be used except in situations where no other available system is practical. The one and one sliding hitch knot should never be used because it is unreliable in stopping a fall. The two and two, or three and three knot (preferable) may be used in special situations; however, care should be taken to limit free fall distance to a minimum because of reduced lifeline strength.

g. *Vertical lifeline considerations.* As required by the standard, each employee

must have a separate lifeline when the lifeline is vertical. The reason for this is that in multiple tie-offs to a single lifeline, if one employee falls, the movement of the lifeline during the arrest of the fall may pull other employees' lanyards, causing them to fall as well.

h. *Planning considerations.* One of the most important aspects of personal fall protection systems is fully planning the system before it is put into use. Probably the most overlooked component is planning for suitable anchorage points. Such planning should ideally be done before the structure or building is constructed so that anchorage points can be incorporated during construction for use later for window cleaning or other building maintenance. If properly planned, these anchorage points may be used during construction, as well as afterwards.

i. *Snap-hook considerations.* Although not required by this standard for all connections, locking snap-hooks designed for connection to any object (of sufficient strength) are highly recommended in lieu of the non-locking type. Locking snap-hooks incorporate a positive locking mechanism in addition to the spring loaded keeper, which will not allow the keeper to open under moderate pressure without someone first releasing the mechanism. Such a feature, properly designed, effectively prevents roll-out from occurring.

As required by the standard, the following connections must be avoided (unless properly designed locking snap-hooks are used) because they are conditions which can result in roll-out when a non-locking snap-hook is used:

- Direct connection of a snap-hook to a horizontal lifeline.
- Two (or more) snap-hooks connected to one dee-ring.
- Two snap-hooks connected to each other.
- A snap-hook connected back on its integral lanyard.
- A snap-hook connected to a webbing loop or webbing lanyard.
- Improper dimensions of the dee-ring, rebar, or other connection point in relation to the snap-hook dimensions which would allow the snap-hook keeper to be depressed by a turning motion of the snap-hook.

j. *Free fall considerations.* The employer and employee should at all times be aware that a system's maximum arresting force is evaluated under normal use conditions established by the manufacturer, and in no case using free fall distance in excess of six feet (1.8 m). A few extra feet of free fall can significantly increase the arresting force on the employee, possibly to the point of causing injury. Because of this, the free fall distance should be kept at a minimum, and, as required by the standard, in no case greater than six feet (1.8 m). To assure this, the tie-off attachment point to the lifeline or anchor should be located at or above the connection point of the fall arrest equipment to the belt or harness. (Since otherwise additional free fall distance is added to the length of the connecting means (*i.e.* lanyard)). Attaching to the working surface will often result in a free fall greater than six

feet (1.8 m). For instance, if a six foot (1.8 m) lanyard is used, the total free fall distance will be the distance from the working level to the body belt (or harness) plus the six feet (1.8 m) of lanyard length. Another important consideration is that the arresting force which the fall system must withstand also goes up with greater distances of free fall, possibly exceeding the strength of the system.

k. *Elongation and deceleration distance considerations.* Other factors involved in a proper tie-off are elongation and deceleration distance. During the arresting of a fall, a lanyard will experience a length of stretching or elongation, whereas activation of a deceleration device will result in a certain stopping distance. These distances should be available with the lanyard or device's instructions and must be added to the free fall distance to arrive at the total fall distance before an employee is fully stopped. The additional stopping distance may be very significant if the lanyard or deceleration device is attached near or at the end of a long lifeline, which may itself add considerable distance due to its own elongation. As required by the standard, sufficient distance to allow for all of these factors must also be maintained between the employee and obstructions below, to prevent an injury due to impact before the system fully arrests the fall. In addition, a minimum of 12 feet (3.7 m) of lifeline should be allowed below the securing point of a rope grab type deceleration device, and the end terminated to prevent the device from sliding off the lifeline. Alternatively, the lifeline should extend to the ground or the next working level below. These measures are suggested to prevent the worker from inadvertently moving past the end of the lifeline and having the rope grab become disengaged from the lifeline.

l. *Obstruction considerations.* The location of the tie-off should also consider the hazard of obstructions in the potential fall path of the employee. Tie-offs which minimize the possibilities of exaggerated swinging should be considered. In addition, when a body belt is used, the employee's body will go through a horizontal position to a jack-knifed position during the arrest of a fall. Thus, obstructions which might interfere with this motion should be avoided or a severe injury could occur.

m. *Other considerations.* Because of the design of some personal fall arrest systems, additional considerations may be required for proper tie-off. For example, heavy deceleration devices of the self-retracting type should be secured overhead in order to avoid the weight of the device having to be supported by the employee. Also, if self-retracting equipment is connected to a horizontal lifeline, the sag in the lifeline should be minimized to prevent the device from sliding down the lifeline to a position which creates a swing hazard during fall arrest. In all cases, manufacturers' instructions should be followed.

#### § 1910.130 Positioning device systems.

1. *Other information.* The following American National Standard is a helpful guideline for window cleaner's positioning device systems:

a. ASME/ANSI A39.1—Safety Requirements for Window Cleaning. In addition to information on the design and use of window cleaner's belts and anchors, other window cleaning procedures are outlined.

2. *Marking.* It is recommended that body belts and pole straps, not designed for use with personal fall arrest systems (not meeting the requirements of § 1910.129) and all chest harnesses, be marked to indicate that they are for use only in positioning device systems.

#### Appendix B to Subpart I—References for Further Information

**Note:** The following appendix to §§ 1910.128–1910.131 of subpart I serves as a non-mandatory guideline to assist employers and employees in complying with these sections and to provide other helpful information. This appendix neither adds to nor detracts from the obligations contained in the OSHA standards.

The following references provide information which may be helpful in understanding and implementing subpart I.

1. "American National Standard Safety Requirements for Fixed Ladders," ANSI A14.3–1982. American National Standards Institute, 1430 Broadway, New York, New York 10018.
2. "American National Standard Safety Requirements for Window Cleaning," ASME/ANSI A39.1a–1988. American National Standards Institute, 1430 Broadway, New York, New York 10018.
3. Chaffin, Don B. and Terrence J. Stobbe. "Ergonomic Considerations Related to Selected Fall Prevention Aspects of Scaffolds and Ladders as Presented in OSHA Standard 29 CFR Part 1910 Subpart D." The University of Michigan, Ann Arbor, Michigan 48104, September 1979. Available from: U.S. Department of Labor, OSHA, 200 Constitution Avenue, NW., Washington, DC 20210.
4. "A Study of Personal Fall-Safety Equipment," NBSIR 76–1146. National Bureau of Standards (NBS), U.S. Department of Commerce, Washington, DC 20234. Available from: National Technical Information Service (NTIS), Springfield, Virginia 22151.
5. Sulowski, Andrew C. "Selecting Fall Arresting Systems," Pp. 55–62. "National Safety News," October 1979, National Safety Council, 425 N. Michigan Avenue, Chicago, Illinois 60611.
6. Sulowski, Andrew C. "Assessment of Maximum Arrest Force," Pp. 55–58. "National Safety News," March 1981, National Safety Council, 425 N. Michigan Avenue, Chicago, Illinois 60611.

#### Appendix C to Subpart I—Test Methods and Procedures for Personal Protective Systems

**Note:** The following appendix to §§ 1910.128–1910.131 of subpart I serves as a non-mandatory guideline to assist employers and employees in complying with these sections and to provide other helpful information. This appendix neither adds to nor detracts from the obligations contained in the OSHA standards.

This appendix contains test methods for personal fall protection systems which may

be used to determine if they meet the system performance criteria specified in §§ 1910.129 and 1910.130.

#### § 1910.129 Test methods for personal fall arrest systems.

1. *General.* The following sets forth test procedures for personal fall arrest systems as defined in § 1910.129.

2. *General test conditions.*

- a. Lifelines, lanyards and deceleration devices should be attached to an anchorage and connected to the body-belt or body harness in the same manner as they would be when used to protect employees.
- b. The anchorage should be rigid, and should not have a deflection greater than .04 inches (1 mm) when a force of 2,250 pounds (10 kN) is applied.
- c. The frequency response of the load measuring instrumentation should be 120 HZ.
- d. The test weight used in the strength and force tests should be a rigid, metal cylindrical or torso-shaped object with a girth of 38 inches plus or minus four inches (96 cm plus or minus 10 cm).
- e. The lanyard or lifeline used to create the free fall distance should be supplied with the system, or in its absence, the least elastic lanyard or lifeline available to be used with the system.
- f. The test weight for each test should be hoisted to the required level and should be quickly released without having any appreciable motion imparted to it.
- g. The system's performance should be evaluated, taking into account the range of environmental conditions for which it is designed to be used.
- h. Following the test, the system need not be capable of further operation.

#### 3. *Strength test.*

- a. During the testing of all systems, a test weight of 300 pounds plus or minus five pounds (135 kg plus or minus 2.5 kg) should be used. (See paragraph 2.d. above.)
- b. The test consists of dropping the test weight once. A new unused system should be used for each test.
- c. For lanyard systems, the lanyard length should be six feet plus or minus two inches (1.83 plus or minus 5 cm) as measured from the fixed anchorage to the attachment on the body belt or body harness.
- d. For rope-grab-type deceleration systems, the length of the lifeline above the centerline of the grabbing mechanism to the lifeline's anchorage point should not exceed two feet (0.61 m).

e. For lanyard systems, for systems with deceleration devices which do not automatically limit free fall distance to two feet (0.61 m) or less, and for systems with deceleration devices which have a connection distance in excess of one foot (0.3 m) (measured between the centerline of the lifeline and the attachment point to the body belt or harness), the test weight should be rigged to free fall a distance of 7.5 feet (2.3 m) from a point that is 1.5 feet (46 cm) above the anchorage point, to its hanging location (six feet below the anchorage). The test weight should fall without interference, obstruction, or hitting the floor or ground during the test. In some cases a non-elastic

wire lanyard of sufficient length may need to be added to the system (for test purposes) to create the necessary free fall distance.

f. For deceleration device systems with integral lifelines or lanyards which automatically limit free fall distance to two feet (0.61 m) or less, the test weight should be rigged to free fall a distance of four feet (1.22 m).

g. Any weight which detaches from the belt or harness should constitute failure for the strength test.

4. *Force test.* a. *General.* The test consists of dropping the respective test weight specified in 4.b.(i) or 4.c.(i) once. A new, unused system should be used for each test.

b. *For lanyard systems.* (i) A test weight of 220 pounds plus or minus three pounds (100 kg plus or minus 1.6 kg) should be used. (See paragraph 2.d., above.)

(ii) Lanyard length should be six feet plus or minus two inches (1.83 m plus or minus 5 cm) as measured from the fixed anchorage to the attachment on the body belt or body harness.

(iii) The test weight should fall free from the anchorage level to its hanging location (a total of six feet (1.83 m) free fall distance) without interference, obstruction, or hitting the floor or ground during the test.

c. *For all other systems.* (i) A test weight of 220 pounds plus or minus three pounds (100 kg plus or minus 1.6 kg) should be used. (See paragraph 2.d., above.)

(ii) The free fall distance to be used in the test should be the maximum fall distance physically permitted by the system during normal use conditions, up to a maximum free fall distance for the test weight of six feet (1.83 m), except as follows:

(A) For deceleration systems which have a connection link or lanyard, the test weight should free fall a distance equal to the connection distance (measured between the centerline of the lifeline and the attachment point to the body belt or harness).

(B) For deceleration device systems with integral lifelines or lanyards which automatically limit free fall distance to two feet (0.61 m) or less, the test weight should free fall a distance equal to that permitted by the system in normal use. (For example, to test a system with a self-retracting lifeline or lanyard, the test weight should be supported and the system allowed to retract the lifeline or lanyard as it would in normal use. The test weight would then be released and the force and deceleration distance measured).

d. *Failure.* A system fails the force test if the recorded maximum arresting force exceeds 1,260 pounds (15.6 kN) when using a body belt, and/or exceeds 2,520 pounds (11.2 kN) when using a body harness.

e. *Distances.* The maximum elongation and deceleration distance should be recorded during the force test.

5. *Deceleration device tests.* a. *General.* The device should be evaluated or tested under the environmental conditions (such as rain, ice, grease, dirt, type of lifeline, etc.) for which the device is designed.

b. *Rope-grab-type deceleration devices.* (i) Devices should be moved on a lifeline 1,000 times over the same length of line a distance of not less than one foot (30.5 cm), and the mechanism should lock each time.



(ii) Unless the device is permanently marked to indicate the type of lifelines which must be used, several types (different diameters and different materials), of lifelines should be used to test the device.

c. *Other self-activating-type deceleration devices.* The locking mechanisms of other self-activating-type deceleration devices designed for more than one arrest should lock each of 1,000 times as they would in normal service.

**§ 1910.130 Test methods for positioning device systems.**

1. *General.* The following sets forth test procedures for positioning device systems as defined in § 1910.130.

2. *Test conditions.*

a. The fixed anchorage should be rigid and should not have a deflection greater than .04 inches (1 mm) when a force of 2,250 pounds (10 kN) is applied.

b. For lineman's body belts and pole straps, the body belt should be secured to a 250 pound (113 kg) bag of sand at a point which simulates the waist of an employee. One end of the pole strap should be attached to the rigid anchorage and the other end to the body belt. The sand bag should be allowed to free fall a distance of four feet (1.2 m). Failure of

the pole strap and body belt should be indicated by any breakage or slippage sufficient to permit the bag to fall free to the ground.

c. For window cleaner's belts, the complete belt should withstand a drop test consisting of a 250 pound (113 kg) weight falling free for a distance of six feet (1.83 m). The weight should be a rigid object with a girth of 38 inches plus or minus four inches (96 cm plus or minus 10 cm). The weight should be placed in the waistband with the belt buckle drawn firmly against the weight, as when the belt is worn by a window cleaner. One belt terminal should be attached to a rigid anchor and the other terminal should hang free. The terminals should be adjusted to their maximum span. The weight fastened in the freely suspended belt should then be lifted exactly six feet (1.83 m) above its "at rest" position and released so as to permit a free fall of six feet (1.83 m) vertically below the point of attachment of the terminal anchor. The belt system should be equipped with devices and instrumentation capable of measuring the duration and magnitude of the arrest forces. Failure of the test should consist of any breakage or slippage sufficient to permit the weight to fall free of the system. In addition, the initial and subsequent

arresting forces should be measured and should not exceed 2,000 pounds (8.5 kN) for more than two milliseconds for the initial impact, nor exceed 1,000 pounds (4.5 kN) for the remainder of the arrest time.

d. All other positioning device systems (except for restraint line systems) should withstand a drop test consisting of a 250 pound (113 kg) weight falling free for a distance of four feet (1.2 m). The weight should be the same as described in paragraph (b)(3), above. The body belt or harness should be affixed to the test weight as it would be to an employee. The system should be connected to the rigid anchor in the manner that the system would be connected in normal use. The weight should be lifted exactly four feet (1.2 m) above its "at rest" position and released so as to permit a vertical free fall of four feet (1.2 m). Failure of the system should be indicated by any breakage or slippage sufficient to permit the weight to fall free to the ground.

(Sections 6(b) and 8, 84 Stat. 1593, 1599, 1600, (29 U.S.C. 655, 657), Secretary of Labor's Order No. 9-83 (48 FR 35736); 29 CFR part 1911)

[FR Doc. 03-10617 Filed 5-1-03; 8:45 am]

**BILLING CODE 4510-26-P**