

§ 229.61

49 CFR Ch. II (10-1-06 Edition)

(c) With a full service application at maximum brake pipe pressure and with communication to the brake cylinders closed, the brakes shall remain applied at least 5 minutes.

(d) Leakage from control air reservoir, related piping, and pneumatically operated controls may not exceed an average of 3 pounds per square inch per minute for 3 minutes.

DRAFT SYSTEM

§ 229.61 Draft system.

(a) A coupler may not have any of the following conditions:

(1) A distance between the guard arm and the knuckle nose of more than  $5/8$  inches on standard type couplers (MCB contour 1904) or more than  $5/16$  inches on D&E couplers.

(2) A crack or break in the side wall or pin bearing bosses outside of the shaded areas shown in Figure 1 or in the pulling face of the knuckle.

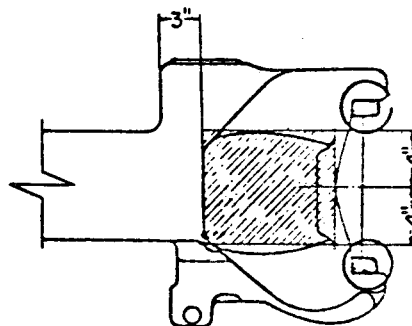

Figure 1

(3) A coupler assembly without anti-creep protection.

(4) Free slack in the coupler or drawbar not absorbed by friction devices or draft gears that exceeds one-half inches.

(5) A broken or cracked coupler carrier.

(6) A broken or cracked yoke.

(7) A broken draft gear.

(b) A device shall be provided under the lower end of all drawbar pins and articulated connection pins to prevent the pin from falling out of place in case of breakage.

exceed 1 inch on non-powered axles and friction bearing powered axles, or  $3/4$  inch on all other powered axles.

(b) The total uncontrolled lateral motion may not exceed  $1/4$  inches on the center axle of three-axle trucks.

§ 229.64 Plain bearings.

A plain bearing box shall contain visible free oil and may not be cracked to the extent that it will leak oil.

§ 229.65 Spring rigging.

(a) Protective construction or safety hangers shall be provided to prevent spring planks, spring seats or bolsters from dropping to track structure in event of a hanger or spring failure.

(b) An elliptical spring may not have its top (long) leaf broken or any other three leaves broken, except when that spring is part of a nest of three or more springs and none of the other springs in the nest has its top leaf or any other

SUSPENSION SYSTEM

§ 229.63 Lateral motion.

(a) Except as provided in paragraph (b), the total uncontrolled lateral motion between the hubs of the wheels and boxes, between boxes and pedestals or both, on any pair of wheels may not

three leaves broken. An outer coil spring or saddle may not be broken. An equalizer, hanger, bolt, gib, or pin may not be cracked or broken. A coil spring may not be fully compressed when the locomotive is at rest.

(c) A shock absorber may not be broken or leaking clearly formed droplets of oil or other fluid.

#### § 229.67 Trucks.

(a) The male center plate shall extend into the female center plate at least  $\frac{3}{4}$  inch. On trucks constructed to transmit tractive effort through the center plate or center pin, the male center plate shall extend into the female center plate at least  $1\frac{1}{2}$  inches. Maximum lost motion in a center plate assemblage may not exceed  $\frac{1}{2}$  inch.

(b) Each locomotive shall have a device or securing arrangement to prevent the truck and locomotive body from separating in case of derailment.

(c) A truck may not have a loose tie bar or a cracked or broken center casting, motor suspension lug, equalizer, hanger, gib or pin. A truck frame may not be broken or have a crack in a stress area that may affect its structural integrity.

#### § 229.69 Side bearings.

(a) Friction side bearings with springs designed to carry weight may not have more than 25 percent of the springs in any one nest broken.

(b) Friction side bearings may not be run in contact unless designed to carry weight. Maximum clearance of side bearings may not exceed one-fourth inch on each side or a total of one-half inch on both sides, except where more than two side bearings are used under the same rigid superstructure. The clearance on one pair of side bearings under the same rigid superstructure shall not exceed one-fourth inch on each side or a total of one-half inch on both sides; the other side bearings under the same rigid superstructure may have one-half inch clearance on each side or a total of 1 inch on both sides. These clearances apply where the spread of the side bearings is 50 inches or less; where the spread is greater, the side bearing clearance may only be increased proportionately.

#### § 229.71 Clearance above top of rail.

No part or appliance of a locomotive except the wheels, flexible nonmetallic sand pipe extension tips, and trip cock arms may be less than  $2\frac{1}{2}$  inches above the top of rail.

#### § 229.73 Wheel sets.

(a) The variation in the circumference of wheels on the same axle may not exceed  $\frac{1}{4}$  inch (two tape sizes) when applied or turned.

(b) The maximum variation in the diameter between any two wheel sets in a three-powered-axle truck may not exceed  $\frac{3}{4}$  inch, except that when shims are used at the journal box springs to compensate for wheel diameter variation, the maximum variation may not exceed  $1\frac{1}{4}$  inch. The maximum variation in the diameter between any two wheel sets on different trucks on a locomotive that has three-powered-axle trucks may not exceed  $1\frac{1}{4}$  inch. The diameter of a wheel set is the average diameter of the two wheels on an axle.

(c) On standard gauge locomotives, the distance between the inside gauge of the flanges on non-wide flange wheels may not be less than 53 inches or more than  $53\frac{1}{2}$  inches. The distance between the inside gauge of the flanges on wide flange wheels may not be less than 53 inches or more than  $53\frac{1}{4}$  inches.

(d) The distance back to back of flanges of wheels mounted on the same axle shall not vary more than  $\frac{1}{4}$  inch.

#### § 229.75 Wheels and tire defects.

Wheels and tires may not have any of the following conditions:

(a) A single flat spot that is  $2\frac{1}{2}$  inches or more in length, or two adjoining spots that are each two or more inches in length.

(b) A gouge or chip in the flange that is more than  $1\frac{1}{2}$  inches in length and  $\frac{1}{2}$  inch in width.

(c) A broken rim, if the tread, measured from the flange at a point five-eighths inch above the tread, is less than  $3\frac{3}{4}$  inches in width.

(d) A shelled-out spot  $2\frac{1}{2}$  inches or more in length, or two adjoining spots that are each two or more inches in length.

(e) A seam running lengthwise that is within  $3\frac{3}{4}$  inches of the flange.