

**§ 571.109 Standard No. 109; New pneumatic tires.**

S1. *Scope.* This standard specifies tire dimensions and laboratory test requirements for bead unseating resistance, strength, endurance, and high speed performance; defines tire load ratings; and specifies labeling requirements for passenger car tires.

S2. *Application.* This standard applies to new pneumatic tires for use on passenger cars manufactured after 1948. However, it does not apply to any tire that has been altered so as to render impossible its use, or its repair for use, as motor vehicle equipment. In addition, S4.3 does not apply to tires certified to comply with S5.5 of § 571.139 and S4.4. does not apply to tires certified to comply with S4 of § 571.139.

S3. *Definitions.*

*Bead* means that part of the tire made of steel wires, wrapped or reinforced by ply cords, that is shaped to fit the rim.

*Bead separation* means a breakdown of bond between components in the bead area.

*Bias ply tire* means a pneumatic tire in which the ply cords that extend to the beads are laid at alternate angles substantially less than 90° to the centerline of the tread.

*Carcass* means the tire structure, except tread and sidewall rubber.

*Chunking* means the breaking away of pieces of the tread or sidewall.

*Cord* means the strands forming the plies in the tire.

*Cord separation* means cords parting away from adjacent rubber compounds.

*Cracking* means any parting within the tread, sidewall, or innerliner of the tire extending to cord material.

*CT* means a pneumatic tire with an inverted flange tire and rim system in which the rim is designed with rim flanges pointed radially inward and the tire is designed to fit on the underside of the rim in a manner that encloses the rim flanges inside the air cavity of the tire.

*Groove* means the space between two adjacent tread ribs.

*Innerliner* means the layer(s) forming the inside surface of a tubeless tire that contains the inflating medium within the tire.

*Innerliner separation* means the parting of the innerliner from cord material in the carcass.

*Load rating* means the maximum load a tire is rated to carry for a given inflation pressure.

*Maximum permissible inflation pressure* means the maximum cold inflation pressure to which a tire may be inflated.

*Maximum load rating* means the load rating at the maximum permissible inflation pressure for that tire.

*Open splice* means any parting at any junction of tread, sidewall, or innerliner that extends to cord material.

*Overall width* means the linear distance between the exteriors of the sidewalls of an inflated tire, including elevations due to labeling, decorations, or protective bands or ribs.

*Ply* means a layer of rubber-coated parallel cords.

*Ply separation* means a parting of rubber compound between adjacent plies.

*Pneumatic tire* means a mechanical device made of rubber, chemicals, fabric and steel or other materials, which, when mounted on an automotive wheel, provides the traction and contains the gas or fluid that sustains the load.

*Radial ply tire* means a pneumatic tire in which the ply cords which extend to the beads are laid at substantially 90° to the centerline of the tread.

*Rim* means a metal support for a tire or a tire and tube assembly upon which the tire beads are seated.

*Section width* means the linear distance between the exteriors of the sidewalls of an inflated tire, excluding elevations due to labeling, decoration, or protective bands.

*Sidewall* means that portion of a tire between the tread and the bead.

*Sidewall separation* means the parting of the rubber compound from the cord material in the sidewall.

*Test rim* means, with reference to a tire to be tested, any rim that is listed as appropriate for use with that tire in accordance with S4.4. For purposes of this section and § 571.110, each rim listing shall include dimensional specifications and a diagram of the rim.

*Tread* means that portion of a tire that comes into contact with the road.

*Tread rib* means a tread section running circumferentially around a tire.

*Tread separation* means pulling away of the tread from the tire carcass.

**S4. Requirements.**

**S4.1 Size and construction.** Each tire shall be designed to fit each rim specified for its size designation in each reference cited in the definition of *test rim* in S3.

**S4.2 Performance requirements.**

**S4.2.1 General.** Each tire shall conform to each of the following:

(a) It shall meet the requirements specified in S4.2.2 for its tire size designation, type, and maximum permissible inflation pressure.

(b) Its maximum permissible inflation pressure shall be either 32, 36, 40, or 60 psi, or 240, 280, 300, 340, or 350 kPa. For a CT tire, the maximum permissible inflation pressure shall be either 290, 330, 350, or 390 kPa.

(c) Its load rating shall be that specified in a submission made by an individual manufacturer, pursuant to S4.4.1(a), or in one of the publications described in S4.4.1(b) for its size designation, type and each appropriate inflation pressure. If the maximum load rating for a particular tire size is shown in more than one of the publications described in S4.4.1(b), each tire of that size designation shall have a maximum load rating that is not less than the published maximum load rating, or if there are differing maximum load ratings for the same tire size designation, not less than the lowest published maximum load rating.

(d) It shall incorporate a tread wear indicator that will provide a visual indication that the tire has worn to a tread depth of 1.6 mm ( $\frac{1}{16}$  inch).

(e) It shall, before being subjected to either the endurance test procedure specified in S5.4 or the high speed performance procedure specified in S5.5, exhibit no visual evidence of tread, sidewall, ply, cord, innerliner, or bead separation, chunking, broken cords, cracking, or open splices.

(f) It shall meet the requirements of S4.2.2.5 and S4.2.2.6 when tested on a test wheel described in S5.4.2.1 either alone or simultaneously with up to 5 other tires.

**S4.2.2 Test requirements.**

**S4.2.2.1 Test sample.** For each test sample use:

(a) One tire for physical dimensions, resistance to bead unseating, and strength, in sequence;

(b) Another tire for tire endurance; and

(c) A third tire for high speed performance.

**S4.2.2.2 Physical dimensions.** The actual section width and overall width for each tire measured in accordance with S5.1, shall not exceed the section width specified in a submission made by an individual manufacturer, pursuant to S4.4.1(a) or in one of the publications described in S4.4.1(b) for its size designation and type by more than:

(a) (For tires with a maximum permissible inflation pressure of 32, 36, or 40 psi) 7 percent, or

(b) (For tires with a maximum permissible inflation pressure of 240, 280, 290, 300, 330, 350 or 390 kPa, or 60 psi) 7 percent or 10 mm (0.4 inches), whichever is larger.

**S4.2.2.3 Tubeless tire resistance to bead unseating.**

**S4.2.2.3.1** When a tubeless tire that has a maximum inflation pressure other than 420 kPa (60 psi) is tested in accordance with S5.2, the applied force required to unseat the tire bead at the point of contact shall be not less than:

(a) 6,670 N (1,500 pounds) for tires with a designated section width of less than 160 mm (6 inches);

(b) 8,890 N (2,000 pounds) for tires with a designated section width of 160 mm (6 inches) or more but less than 205 mm (8 inches);

(c) 11,120 N (2,500 pounds) for tires with a designated section width of 205 mm (8 inches) or more, using the section width specified in a submission made by an individual manufacturer, pursuant to S4.4.1(a), or in one of the publications described in S4.4.1(b) for the applicable tire size designation and type.

**S4.2.2.3.2** When a tire that has a maximum inflation pressure of 420 kPa (60 psi) is tested in accordance with S5.2, the applied force required to unseat the bead at the point of contact shall be not less than:

(a) 6,670 N (1,500 pounds) for tires with a maximum load rating of less than 399 kg (880 pounds);

(b) 8,890 N (2,000 pounds) for tires with a maximum load rating of 399 kg (880 pounds) or more but less than 635 kg (1,400 pounds);

(c) 11,120 N (2,500 pounds) for tires with a maximum load rating of 635 kg (1,400 pounds) or more, using the maximum load rating marked on the sidewall of the tire.

S4.2.2.4 *Tire strength.* Each tire shall meet the requirements for minimum breaking energy specified in Table 1 when tested in accordance with S5.3.

S4.2.2.5 *Tire endurance.* When the tire has been subjected to the laboratory endurance test specified in S5.4, using a test rim that undergoes no permanent deformation and allows no loss of air through the portion that it comprises of the tire-rim pressure chamber:

(a) There shall be no visual evidence of tread, sidewall, ply, cord, innerliner, or bead separation, chunking, broken cords, cracking, or open splices.

(b) The tire pressure at the end of the test shall be not less than the initial pressures specified in S5.4.1.1.

S4.2.2.6 *High speed performance.* When the tire has been subjected to the laboratory high speed performance test specified in S5.5, using a test rim that undergoes no permanent deformation and allows no loss of air through the portion that it comprises of the tire-rim pressure chamber, the tire shall meet the requirements set forth in S4.2.2.5 (a) and (b).

S4.3 *Labeling Requirements.* Except as provided in S4.3.1 and S4.3.2 of this standard, each tire, except for those certified to comply with S5.5 of §571.139, shall have permanently molded into or onto both sidewalls, in letters and numerals not less than 0.078 inches high, the information shown in paragraphs S4.3 (a) through (g) of this standard. On at least one sidewall, the information shall be positioned in an area between the maximum section width and bead of the tire, unless the maximum section width of the tire falls between the bead and one-fourth of the distance from the bead to the shoulder of the tire. For tires where the maximum section width falls in that area, locate all required labeling between the bead and a point one-half the distance from the bead to the shoulder of the tire. However, in no

case shall the information be positioned on the tire so that it is obstructed by the flange or any rim designated for use with that tire in Standards Nos. 109 and 110 (Sec. 571.109 and Sec. 571.110 of this part).

(a) One size designation, except that equivalent inch and metric size designations may be used;

(b) Maximum permissible inflation pressure;

(c) Maximum load rating;

(d) The generic name of each cord material used in the plies (both sidewall and tread area) of the tire;

(e) Actual number of plies in the sidewall, and the actual number of plies in the tread area if different;

(f) The words “tubeless” or “tube type” as applicable; and

(g) The word “radial” if the tire is a radial ply tire.

S4.3.1 Each tire shall be labeled with the symbol DOT in the manner specified in part 574 of this chapter, which shall constitute a certification that the tire conforms to applicable Federal motor vehicle safety standards.

S4.3.2 Each tire shall be labeled with the name of the manufacturer, or brand name and number assigned to the manufacturer in the manner specified in part 574.

S4.3.3 [Reserved]

S4.3.4 If the maximum inflation pressure of a tire is 240, 280, 290, 300, 330, 340, 350, or 390 kPa, then:

(a) Each marking of that inflation pressure pursuant to S4.3(b) shall be followed in parenthesis by the equivalent inflation pressure in psi, rounded to the next higher whole number; and

(b) Each marking of the tire’s maximum load rating pursuant to S4.3(c) in kilograms shall be followed in parenthesis by the equivalent load rating in pounds, rounded to the nearest whole number.

S4.3.5 If the maximum inflation pressure of a tire is 420 kPa (60 psi), the tire shall have permanently molded into or onto both sidewalls, in letters and numerals not less than 12.7 mm (½ inch), the words “Inflate to 420 kPa (60 psi)”. On both sidewalls, the words shall be positioned in an area between the tire shoulder and the bead of the tire. However, in no case shall the

words be positioned on the tire so that they are obstructed by the flange of any rim designated for use with that tire in this standard or in Standard No. 110 (§571.110 of this part).

S4.4 *Tire and rim matching information.*

S4.4.1 Each manufacturer of tires not certified to comply with S4 of §571.139 shall ensure that a listing of the rims that may be used with each tire that he produces is provided to the public. A listing compiled in accordance with paragraph (a) of S4.4.1 of this standard need not include dimensional specifications or diagram of a rim if the rim's dimensional specifications and diagram are contained in each listing published in accordance with paragraph (b) of S4.4.1 of this standard. The listing shall be in one of the following forms:

(a) Listed by manufacturer name or brand name in a document furnished to dealers of the manufacturer's tires, to any person upon request, and in duplicate to the Docket Section, National Highway Traffic Safety Administration, 400 Seventh Street SW., Washington, DC 20590; or

(b) Contained in publications, current at the date of manufacture of the tire or any later date, of at least one of the following organizations:

The Tire and Rim Association  
 The European Tyre and Rim Technical Organisation  
 Japan Automobile Tire Manufacturers' Association, Inc.  
 Deutsche Industrie Norm  
 British Standards Institution  
 Scandinavian Tire and Rim Organization  
 The Tyre and Rim Association of Australia

S4.4.2 Information contained in any publication specified in S4.4.1(b) of this standard which lists general categories of tires and rims by size designation, type of construction and/or intended use, shall be considered to be manufacturer's information pursuant to S4.4.1 of this standard for the listed tires and rims, unless the publication itself or specific information provided according to S4.4.1(a) of this standard indicates otherwise.

S5. *Test procedures.*

S5.1 *Physical Dimensions.* Determine tire physical dimensions under uniform ambient conditions as follows:

(a) Mount the tire on a test rim having the test rim width specified in a submission made by an individual manufacturer, pursuant to S4.4.1(a), or in one of the publications described in S4.4.1(b) for that tire size designation and inflate it to the applicable pressure specified in Table II.

(b) Condition it at ambient room temperature for at least 24 hours.

(c) Readjust pressure to that specified in (a).

(d) Caliper the section width and overall width at six points approximately equally spaced around the tire circumference.

(e) Record the average of these measurements as the section width and overall width, respectively.

(f) Determine tire outer diameter by measuring the maximum circumference of the tire and dividing this dimension by pi (3.14).

S5.2 *Tubeless tire bead unseating resistance.*

S5.2.1 *Preparation of tire-wheel assembly.*

S5.2.1.1 Wash the tire, dry it at the beads, and mount it without lubrication or adhesives on a clean, painted test rim.

S5.2.1.2 Inflate it to the applicable pressure specified in Table II at ambient room temperature.

S5.2.1.3 Mount the wheel and tire in a fixture shown in Figure 1, and force the bead unseating block shown in Figure 2 or Figure 2A against the tire sidewall as required by the geometry of the fixture. However, in testing a tire that has an inflation pressure of 60 psi, only use the bead unseating block described in Figure 2A.

S5.2.2 *Test procedure.*

S5.2.2.1 Apply a load through the block to the tire's outer sidewall at the distance specified in Figure 1 for the applicable wheel size at a rate of 50 mm (2 inches) per minute, with the load arm substantially parallel to the tire and rim assembly at the time of engagement.

S5.2.2.2 Increase the load until the bead unseats or the applicable value specified in S4.2.2.3 is reached.

S5.2.2.3 Repeat the test at least four places equally spaced around the tire circumference.

S5.3 *Tire strength.*

S5.3.1 *Preparation of tire.*

S5.3.1.1 Mount the tire on a test rim and inflate it to the applicable pressure specified in Table II.

S5.3.1.2 Condition it at room temperature for at least 3 hours; and

S5.3.1.3 Readjust its pressure to that specified in S5.3.1.1.

S5.3.2 *Test procedure.*

S5.3.2.1 Force a 19 mm (¾ inch) diameter cylindrical steel plunger with a hemispherical end perpendicularly into the tread rib as near to the centerline as possible, avoiding penetration into the tread groove, at the rate of 50 mm (2 inches) per minute.

S5.3.2.2 Record the force and penetration at five test points equally spaced around the circumference of the tire. If the tire fails to break before the plunger is stopped by reaching the rim, record the force and penetration as the rim is reached and use these values in S5.3.2.3.

S5.3.2.3 Compute the breaking energy for each test point by means of one of the two following formulas:

$$W = [(F \times P) / 2] \times 10^{-3} \text{ (joules)}$$

Where

W=Energy, in joules;  
F=Force, Newtons; and  
P=Penetration, mm; or

$$W = [(F \times P) / 2]$$

Where

W=Energy, inch-pounds;  
F=Force, pounds; and  
P=Penetration, inches.

S5.3.2.4 Determine the breaking energy value for the tire by computing the average of the five values obtained in accordance with S5.3.2.3.

S5.4 *Tire endurance.*

S5.4.1 *Preparation of tire.*

S5.4.1.1 Mount a new tire on a test rim and inflate it to the applicable pressure specified in Table II.

S5.4.1.2 Condition the tire assembly to 38° ±3 °C (100° ±5 °F) for at least three hours.

S5.4.1.3 Readjust tire pressure to that specified in S5.4.1.1 immediately before testing.

S5.4.2 *Test procedure.*

S5.4.2.1 Mount the tire and wheel assembly on a test axle and press it against a flat-faced steel test wheel

1708 mm (67.23 inches) in diameter and at least as wide as the section width of the tire to be tested or an approved equivalent test wheel, with the applicable test load specified in the table in S5.4.2.3 for the tire's size designation, type and maximum permissible inflation pressure.

S5.4.2.2 During the test, the air surrounding the test area shall be 38° ±3 °C (100° ±5 °F).

S5.4.2.3 Conduct the test at 80 kilometers per hour (km/h)(50 miles per hour) in accordance with the following schedule without pressure adjustment or other interruptions:

The loads for the following periods are the specified percentage of the maximum load rating marked on the tire sidewall:

	Percent
4 hours .....	85
6 hours .....	90
24 hours .....	100

S5.4.2.4 Immediately after running the tire the required time, measure its inflation pressure. Allow the tire to cool for one hour. Then deflate the tire, remove it from the test rim, and inspect it for the conditions specified in S4.2.2.5(a).

S5.5 High speed performance.

S5.5.1 After preparing the tire in accordance with S5.4.1, mount the tire and wheel assembly in accordance with S5.4.2.1, and press it against the test wheel with a load of 88 percent of the tire's maximum load rating as marked on the tire sidewall.

S5.5.2 Break in the tire by running it for 2 hours at 80 km/h (50 mph).

S5.5.3 Allow to cool to 38° ±3 °C (100° ±5 °F) and readjust the inflation pressure to the applicable pressure specified in Table II.

S5.5.4 Without readjusting inflation pressure, test at 121 km/h (75 mph) for 30 minutes, 129 km/h (80 mph) for 30 minutes, and 137 km/h (85 mph) for 30 minutes.

S5.5.5 Immediately after running the tire the required time, measure its inflation pressure. Allow the tire to cool for one hour. Then deflate the tire, remove it from the test rim, and inspect it for the conditions specified in S4.2.2.5(a).

§ 571.109

49 CFR Ch. V (10-1-06 Edition)

S6. *Nonconforming tires.* No tire that is designed for use on passenger cars and manufactured on or after October 1, 1972, but does not conform to all the requirements of this standard, shall be

sold, offered for sale, introduced or delivered for introduction into interstate commerce, or imported into the United States, for any purpose.

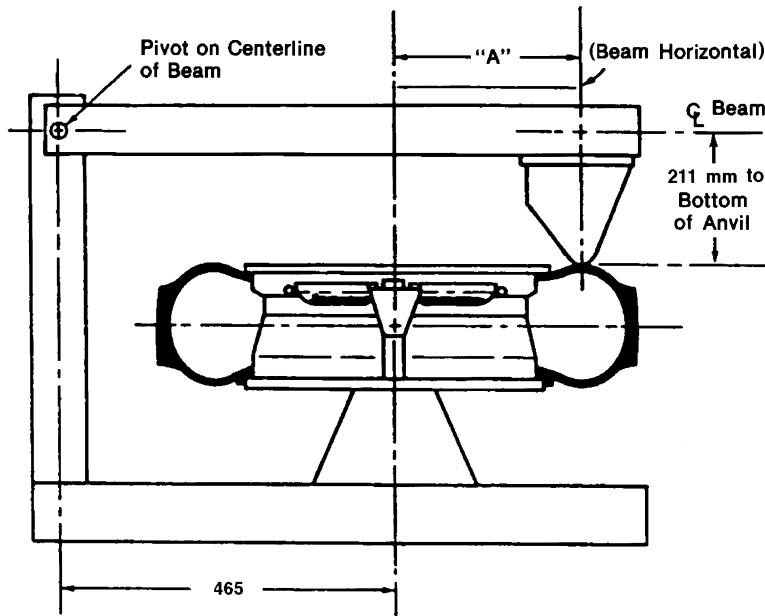

**Figure 1.—Bead Unseating Fixture  
All Dimensions in Millimeters (mm)**

FIGURES FOR STANDARD 109

Wheel sizes	Dimension "A" for tires with maximum inflation pressure			
	Other than 60 psi	Other than 420 kPa	60 psi	420 kPa
19 .....	13.00 in .....	330	12.00 in .....	305
18 .....	12.50 in .....	318	11.40 in .....	290
17 .....	12.00 in .....	305	10.60 in .....	269
16 .....	11.50 in .....	292	9.90 in .....	251
15 .....	11.00 in .....	279	9.40 in .....	239
14 .....	10.50 in .....	267	8.90 in .....	226
13 .....	10.00 in .....	254	8.40 in .....	213
12 .....	9.50 in .....	241	.....	.....
11 .....	9.00 in .....	229	.....	.....
10 .....	8.50 in .....	216	.....	.....
320 .....	8.50 in .....	216	.....	.....
340 .....	9.00 in .....	229	.....	.....
345 .....	9.25 in .....	235	.....	.....
365 .....	9.75 in .....	248	.....	.....
370 .....	10.00 in .....	254	.....	.....
390 .....	11.00 in .....	279	.....	.....
415 .....	11.50 in .....	292	.....	.....
400 <sup>1</sup> .....	10.25 in .....	260	.....	.....
425 <sup>1</sup> .....	10.75 in .....	273	.....	.....
450 <sup>1</sup> .....	11.25 in .....	286	.....	.....

FIGURES FOR STANDARD 109—Continued

Wheel sizes	Dimension "A" for tires with maximum inflation pressure			
	Other than 60 psi	Other than 420 kPa	60 psi	420 kPa
475 <sup>1</sup> .....	11.75 in .....	298	.....	.....
500 <sup>1</sup> .....	12.25 in .....	311	.....	.....

<sup>1</sup> For CT Tires only.

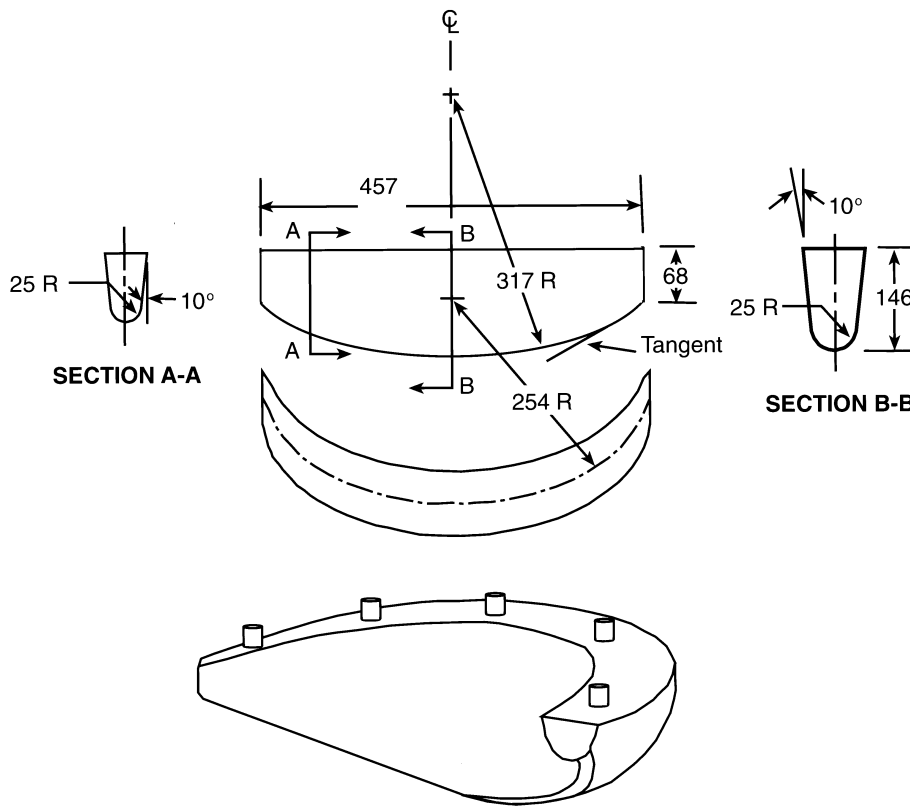

MATERIAL: Cast Aluminum 355  
 T-6 Condition  
 Finish-1.3 Micrometer (um)

**Figure 2. DIAGRAM OF BEAD UNSEATING BLOCK**  
**All dimensions in millimeters (mm)**

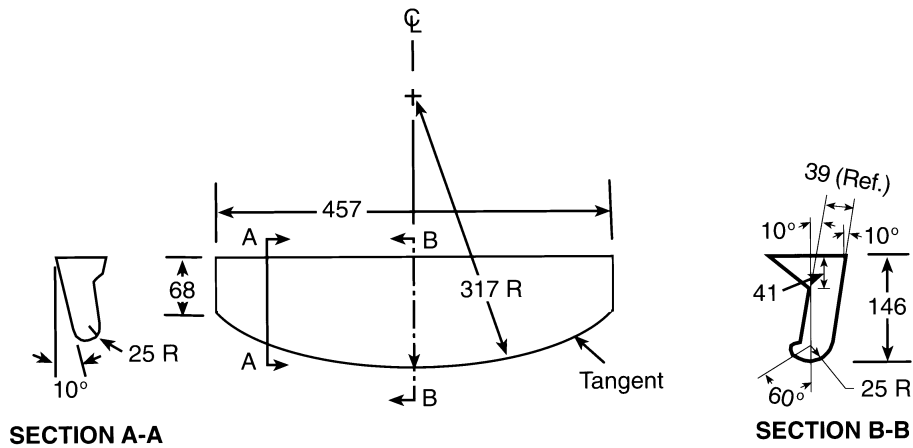

SECTION A-A

SECTION B-B

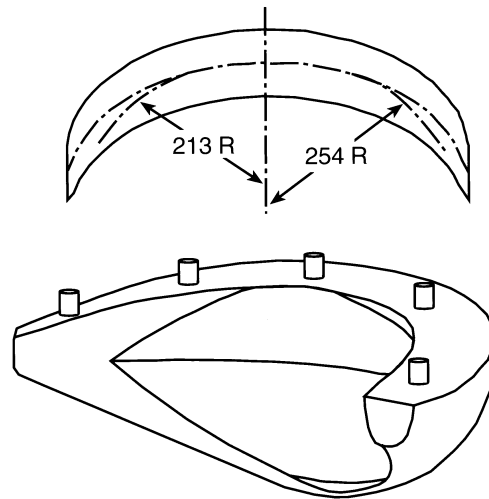

MATERIAL: Cast Aluminum 355  
 T-6 Condition  
 Finish-1.3 Micrometer (um)

**Figure 2A. DIAGRAM OF BEAD UNSEATING BLOCK**  
**All dimensions in millimeters (mm)**

APPENDIX A—FEDERAL MOTOR VEHICLE  
 SAFETY STANDARD NO. 109

The following tables list tire sizes and tire constructions with proper load and inflation values. The tables group tires of related constructions and load/inflation values. Persons

requesting the addition of new tire sizes to the tables or the addition of tables for new tire constructions may, when the additions requested are compatible with existent groupings, or when adequate justification for new tables exists, submit five (5) copies of information and data supporting the request to

the Vehicle Dynamics Division, Office of Crash Avoidance Standards, National Highway Traffic Safety Administration, 400 Seventh Street SW., Washington, DC 20590.

The information should contain the following:

1. The tire size designation, and a statement either that the tire is an addition to a category of tires listed in the tables or that it is in a new category for which a table has not been developed.
2. The tire dimensions, including aspect ratio, size factor, section width, overall width, and test rim size.
3. The load-inflation schedule of the tire.

4. A statement as to whether the tire size designation and load inflation schedule has been coordinated with the Tire and Rim Association, the European Tyre and Rim Technical Organisation, the Japan Automobile Tire Manufacturers' Association, Inc., the Deutsche Industrie Norm, the British Standards Institution, the Scandinavian Tire and Rim Organization, and the Tyre and Rim Association of Australia.

5. Copies of test data sheets showing test conditions, results and conclusions obtained for individual tests specified in §571.109.

6. Justification for the additional tire sizes.

TABLE I-A—FOR BIAS PLY TIRES WITH DESIGNATED SECTION WIDTH OF 152 MM (6 INCHES) AND ABOVE

Cord material	32 psi	36 psi	40 psi	240 kPa	280 kPa	300 kPa	340 kPa
Rayon:							
(in-lbs) .....	1,650	2,574	3,300	1,650	3,300	1,650	3,300
(joules) .....	186	291	373	186	373	186	373
Nylon or polyester:							
(in-lbs) .....	2,600	3,900	5,200	2,600	5,200	2,600	5,200
(joules) .....	294	441	588	294	588	294	588

TABLE I-B—FOR BIAS PLY TIRES WITH DESIGNATED SECTION WIDTH BELOW 152 MM (6 INCHES)

Cord material	32 psi	36 psi	40 psi	240 kPa	280 kPa	300 kPa	340 kPa
Rayon:							
(in-lbs) .....	1,000	1,875	2,500	1,000	2,500	1,000	2,500
(joules) .....	113	212	282	113	282	113	282
Nylon or polyester:							
(in-lbs) .....	1,950	2,925	3,900	1,950	3,900	1,950	3,900
(joules) .....	220	330	441	220	441	220	441

TABLE I-C—FOR RADIAL PLY TIRES

Size designation	Maximum permissible inflation											
	Tires other than CT tires								CT tires			
	psi			kPa					kPa			
	32	36	40	240	280	300	340	350	290	330	350	390
Below 160 mm:												
(in-lbs) .....	1,950	2,925	3,900	1,950	3,900	1,950	3,900	1,950	1,950	3,900	1,950	3,900
(joules) .....	220	330	441	220	441	220	441	220	220	441	220	441
160 mm or above:												
(in-lbs) .....	2,600	3,900	5,200	2,600	5,200	2,600	5,200	2,600	2,600	5,200	2,600	5,200
(joules) .....	294	441	588	294	588	294	588	294	294	588	294	588

TABLE I-D—FOR TIRES WITH 420 kPa (60 PSI) MAXIMUM PERMISSIBLE INFLATION PRESSURE AND MAXIMUM LOAD RATING 399 KG (880 LB) AND ABOVE

Cord material	Inch-pounds joules (J)
Rayon .....	1,650 inch pounds 186 joules (J).
Nylon or Polyester .....	2,600 inch pounds 294 joules (J).

TABLE I-E—FOR TIRES WITH 420 kPa (60 PSI) MAXIMUM PERMISSIBLE INFLATION PRESSURE AND MAXIMUM LOAD RATING BELOW 399 KG (880 LB)

Cord material	Inch-pounds joules (J)
Rayon .....	1,000 inch pounds 113 joules (J).

§ 571.109, Nt.

49 CFR Ch. V (10–1–06 Edition)

TABLE I-E—FOR TIRES WITH 420 kPa (60 PSI) MAXIMUM PERMISSIBLE INFLATION PRESSURE AND MAXIMUM LOAD RATING BELOW 399 KG (880 LB)—Continued

Cord material	Inch-pounds joules (J)
Nylon or Polyester .....	1,950 inch pounds 220 joules (J).

TABLE II—TEST INFLATION PRESSURES  
[Maximum permissible inflation pressure to be used for the following test]

Test type	Tires other than CT tires										CT tires			
	psi					kPa					kPa			
	32	36	40	60	240	280	300	340	350	290	300	350	390	
Physical dimensions, bead unseating, tire strength, and tire endurance .....	24	28	32	52	180	220	180	220	180	270	270	230	270	
High speed performance .....	30	34	38	58	220	260	220	260	220	270	310	270	310	

[38 FR 30235, Nov. 1, 1973]

EDITORIAL NOTE: For FEDERAL REGISTER citations affecting § 571.109, see the List of CFR Sections Affected, which appears in the Finding Aids section of the printed volume and on GPO Access.

EFFECTIVE DATE NOTES: 1. At 68 FR 38147, June 26, 2003, § 571.109 was amended by revising the heading and S2, effective June 1, 2007. At 71 FR 877, Jan. 6, 2006, the effective date was delayed until Sept. 1, 2007. For the convenience of the user, the revised and added text is set forth as follows:

**§ 571.109 Standard No. 109—New Pneumatic Bias Ply and Certain Specialty Tires.**

\* \* \* \* \*

S2. *Application.* This standard applies to new pneumatic radial tires for use on passenger cars manufactured before 1975, new pneumatic bias ply tires, and ST, FI, and 8–12 rim diameter and below tires for use on passenger cars manufactured after 1948. However, it does not apply to any tire that has been so altered so as to render impossible its

use, or its repair for use, as motor vehicle equipment.

\* \* \* \* \*

2. At 71 FR 885, Jan. 6, 2006, § 571.109 was amended by revising the section heading, S2, and the Table located below Figure 1, effective June 1, 2007. For the convenience of the user, the revised text is set forth as follows:

**§ 571.109 Standard No. 109—New pneumatic and certain specialty tires.**

\* \* \* \* \*

S2. *Application.* This standard applies to new pneumatic radial tires for use on passenger cars manufactured before 1975, and new pneumatic bias ply tires for use on passenger cars manufactured after 1948.

\* \* \* \* \*

FIGURES FOR FMVSS No. 109

Wheel size	Dimension “A” for tires with maximum inflation pressure			
	Other than 60 psi (in)	Other than 420 kPa	60 psi (in)	420 kPa
20 .....	13.50	345	.....	.....
19 .....	13.00	330	12.00	305
18 .....	12.50	318	11.40	290
17 .....	12.00	305	10.60	269
16 .....	11.50	292	9.90	251
15 .....	11.00	279	9.40	239
14 .....	10.50	267	8.90	226
13 .....	10.00	254	8.40	213
12 .....	9.50	241	.....	.....
11 .....	9.00	229	.....	.....
10 .....	8.50	216	.....	.....